

## ROTARY UNION

### Technical Manual



# FILTON® ROTARY UNIONS. . . AN INTRODUCTION

A Rotary Union is a device which can be connected to a rotating shaft and allows for the leak-proof transfer of fluids to and from a stationary source service. When selecting the correct rotary union model for your particular application, the vital components to consider include the rotary seals and the bearing support systems.

## ROTARY SEALS:

1) **Filton® Bellows Seal:** For the majority of applications, the Bellows Seal is the most efficient seal used. It does not contain any elastomeric components which make it suitable for rotary applications ranging in ambient temperatures from subzero to 300°C. It is particularly useful for steam, hot water and heat transfer applications.

2) **Filton® Mechanical Seal:** The Mechanical Seal is generally used for higher pressure and higher speed applications such as hydraulic systems and machine tools. It is also used in applications where higher speed shafts are involved. The springs of the mechanical seal are located outside of the fluid flow area which improves performance.

Both variations of seal provide exceptional quality of the seal contact faces; each are lapped to a high degree of accuracy and are checked optically to ensure that the correct flatness is obtained.

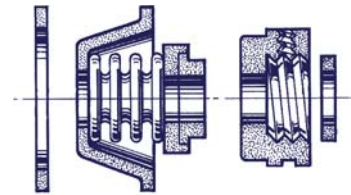

BELLOWS SEAL

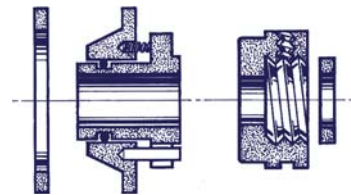

MECHANICAL SEAL

## BEARING SUPPORTS SYSTEMS:

Depending on your application, there are a range of different bearings that are available including standard ball bearings, angular contact bearings, carbon journal and thrust bearings. Although the ball bearings used generally have an upper temperature limit of 180°C, they are more suitable for higher speed applications and the upper temperature limits can be exceeded in some cases with special bearings and lubrication. Carbon bearings, although they have lower speed limit values, are useful for higher temperatures up to 300°C. For more information about bearing options, please contact us.

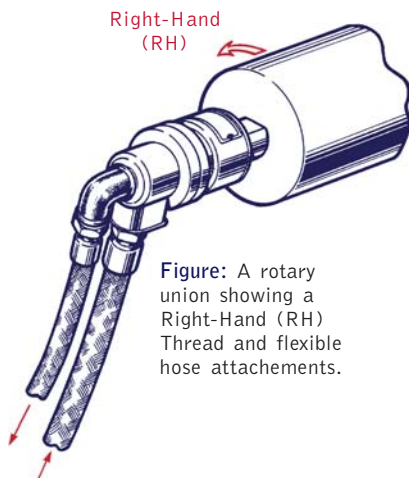

Figure: A rotary union showing a Right-Hand (RH) Thread and flexible hose attachments.

## MAKING THE RIGHT CHOICE. . .

Making the right choice of rotary union for your application can be a detailed exercise. This Manual has been designed to provide you with the technical information needed to make an informed decision about individual models as well as information detailing installation procedures, general operational guidelines, maintenance recommendations, lubrication parameters and detailed part number schematics.

It is important to keep in mind that other factors can have major impacts on performance and rotary union life including the type (and temperature) of the fluid being transferred, the flow rate and pressure, the ambient temperature and rotational speed, the direction of rotation and the working cycle. We encourage you to contact us whenever more detailed information is required, including customization possibilities.

**\*Please Note:** Throughout this manual, the designation for pipe threads are indicated by:  
"G" - Parallel pipe thread to BS.2779 & ISO 228/1 (formerly designated B.S.P. - Parallel)  
"R" - Tapered pipe thread to BS.21 & ISO.7/1 (formerly designated B.S.P. - Taper)

# TABLE OF CONTENTS

## Rotary Union Models

Model R.E. (1/4" to 1-1/4") . . . . .	Page 4 - 7
• Description and Types	
• Model and Dimensional Information	
• Flow Capacity	
• Maximum Operating Recommendations	
• Installation Requirements	
• Part Identification	
• Maintenance and Overhaul	
• Lubrication	
Model P.B. (1/2" to 1") . . . . .	Page 8 - 11
Model R.E.B (1-1/2" to 6"). . . . .	Page 12 - 15
Model C.B. High Temperature (1/4" to 1-1/4") . . . . .	Page 16 - 19
Model C.B.N. High Temperature (1-1/2" to 6") . . . . .	Page 20 - 23

## Additional Rotary Union Models . . . . . Page 24

- Model L.C. Light Duty (1/4" - 3/4")
- Model P.N. Pneumatic (1/4" - 3/4")
- Model M.C.T. Machine Tool (1/4" - 1")
- Model I.N.T. Limited Space (1/4" - 1")

## Special Rotary Union Models . . . . . Page 25

- 3-port
- Piggyback
- Liquid bottling / canning
- Multi-port
- Overshaft

## Special Connections . . . . . Page 26

- Screw Threads
- Flanges
- Standard Spindle Flange Sizes and Dimensions

## Accessories . . . . . Page 27-28

- Syphon Elbows
- Flexible Hoses

## Typical Applications . . . . . Page 29

## Health and Safety . . . . . Page 29

## Cross Reference Charts . . . . . Page 30-31

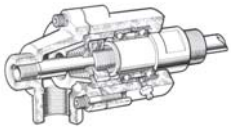

# ROTARY (R.E.) UNIONS

1/4" to 1-1/4"

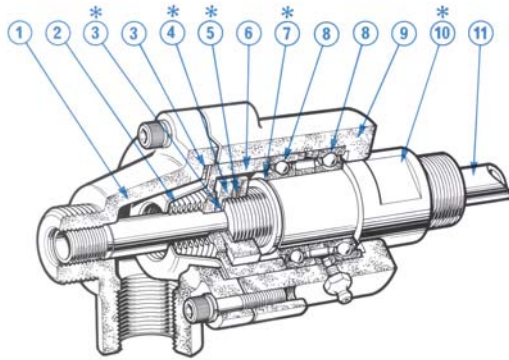

\* Note: The components indicated by ( \* ) rotate with the machine shaft.

## Rotary (R.E.) Union - Type S.T.

1. Adaptor, high quality cast-iron
2. Bellows sub-assembly, brazed stainless steel
3. Gaskets
4. Seal ring sub-assembly, steel / carbon
5. Locking screw, heat treated steel
6. Spacer
7. Circlip
8. Ball bearings
9. Body - high quality cast iron
10. Rotary spindle, steel
11. Centre tube (if ordered)

### Description

The rotary R.E. union is a self-contained, self-supporting rotary seal for the leak-proof transfer of fluids such as steam, water, air and oil to and from rotating machine shafts. The type of rotary seal fitted to this model is a Filton® Bellows Seal containing a flexible stainless steel bellows which is self-adjusting, eliminating the maintenance common with conventional packed glands. Rotary sealing is created by relative rotation between extremely flat sealing faces (see item #2 and #4 in diagram above) held in contact by the spring characteristics of the bellows combined with an additional sealing force created by the pressure of the fluid passing through the rotary union. The bearings fitted to the union are standard ball bearings which are supplied with the initial lubrication completed prior to shipping. There are three variations of the stationary adapter end:

#### 1) Type B.E. - Single Flow

A single flow union suitable for transferring fluid in to or out of rotating machines.

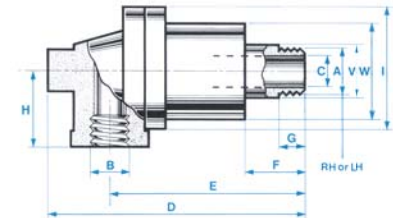

Type B.E.

#### 2) Type S.T. - Double Flow (Stationary Center Tube)

Fitted with an adapter suitable for double flow with a stationary center tube. This gives flow areas through the center tube and annulus. The center tube - provided only if ordered - is fixed to the union end by means of a screw thread (dimension "O"). Flow can pass in through the center tube and return through the annulus or be reversed. For steam applications, the center tube is curved to reach the condensate in the bottom of the cylinder. If the roll neck diameter to length ratio prevents the use of a curved tube, a syphon elbow can be specified instead. See the Accessory Section or contact us for more information about the options available.

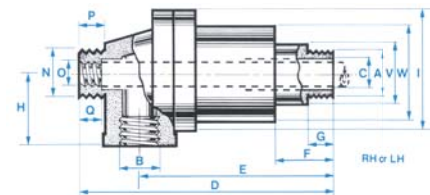

Type S.T.

#### 3) Type R.S. - Double Flow (Rotary Center Tube)

Fitted with an adapter suitable for a rotating center tube which must be located and driven by the machine. The center tube - provided only if ordered - rotates in a bush. Flow can pass in through the center tube with the return through the annulus or be reversed. The center tube "sealing" system allows for a slight internal leakage between the supply and return lines. If these fluids must not mix, alternate designs are available. Please contact us for additional information.

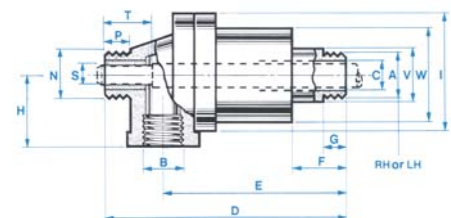

Type R.S.

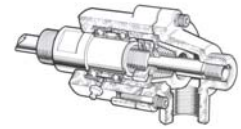

## Model and Dimensional Information

Nominal Size	Rotary (R.E.) Union - Model Part Number			Dimensions (mm unless specified otherwise)													
	B.E. (R or L)	S.T. (R or L)	R.S. (R or L)	A, B, N <sup>(i)</sup>	C	D	E	F	G, P	H	I	O	Q	S	T	V	W
8 (1/4")	14642	14643M	17196	G. 1/4"	6	117	94	22	11	30	57	M5 x 0.8	6	4.75 / 4.72	25	24	44
10 (3/8")	14636	14637M	17197	G. 3/8"	10	121	97	25	13	30	57	M6 x 1.0	6	6.35 / 6.32	25	24	44
15 (1/2")	14536	14535	16657	G. 1/2"	13	167	130	29	16	44	83	G. 1/8"	6	9.52 / 9.50	40	38	63
20 (3/4")	14460	14534	16659	G. 3/4"	18	173	133	32	19	44	83	G. 1/4"	10	12.70 / 12.67	40	38	63
25 (1")	14396	14542	16661	G. 1"	22	197	149	48	22	54	105	G. 3/8"	10	15.87 / 15.85	45	43	83
32 (1-1/4")	14377	14379	16663	G. 1-1/4"	30	227	170	51	25	70	121	G. 1/2"	13	19.05 / 19.02	50	55	95

(i) "G" is the designation for parallel pipe threads to BS.2779 and ISO 228/1.

## Flow Capacity

Nominal Size	Rotary (R.E.) Union - Model	Water <sup>(ii)</sup>		Steam <sup>(iii)</sup>	Air <sup>(iv)</sup>
		m <sup>3</sup> /h	l/min	kg/h	m <sup>3</sup> /h
8 (1/4")	B.E.	0.3	5.0	11	11
	S.T. / R.S.	0.05	0.8	3.4	2
10 (3/8")	B.E.	0.8	13.3	31	29
	S.T. / R.S.	0.1	1.7	16	4
15 (1/2")	B.E.	1.7	28.3	61	58
	S.T. / R.S.	0.3	5	27	10
20 (3/4")	B.E.	2.7	45	101	96
	S.T. / R.S.	0.6	10	41	22
25 (1")	B.E.	4.1	68.3	151	144
	S.T. / R.S.	1.8	30	56	44
32 (1-1/4")	B.E.	7.6	127	280	267
	S.T. / R.S.	2.1	35	133	74

(ii) Flow measured in cubic metres/hour at a velocity of 3 metres/second. (Also applies to other liquids.)

(iii) Flow in kilograms/hour at a velocity of 30 metres/second and a pressure of 6 bar.

(iv) Flow in cubic metres/hour free air at a velocity of 15 metres/second and a pressure of 6 bar.

## Maximum Operating Recommendations

Fluids: Water, steam, mineral oils and compressed air (lubricated).  
All fluids should be clean and free from abrasive particles.

Pressure: 17 bar maximum.

Vacuum: 740mm Hg. maximum (specify vacuum and we will test for this).

Temperature: -20°C to 180°C (and up to 200°C with special lubrication).

Speed: 1000 r.p.m. maximum for sizes up to 25 (1") and 800 r.p.m. maximum for sizes above.

Storage: Store indoors in a dry area between the temperature ranges of -10°C to 30°C.

**\* Note:** It is not advisable to exceed or combine maximums.

## Installation Procedures

- 1) A suitable run-in period before fitting is recommended. Rotate the R.E. at 300 r.p.m. for 15 minutes.
- 2) Add system liquid if seals squeak.
- 3) A torque arrestor may be fitted, but this must not restrict the rotary union.
- 4) Ensure that the spindle thread is RH or LH to suit the direction of rotation of the machine shaft.
- 5) If the machine shaft reverses direction of rotation, securely lock the spindle or (preferably) use a flanged connection.
- 6) DO NOT fix valves etc. directly on to the rotary union.
- 7) DO NOT connect with rigid pipe.
- 8) DO NOT clamp the rotary union.

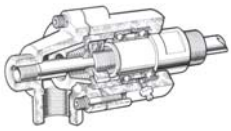

# ROTARY (R.E.) UNIONS

1/4" to 1-1/4"

## Installation (Continued)

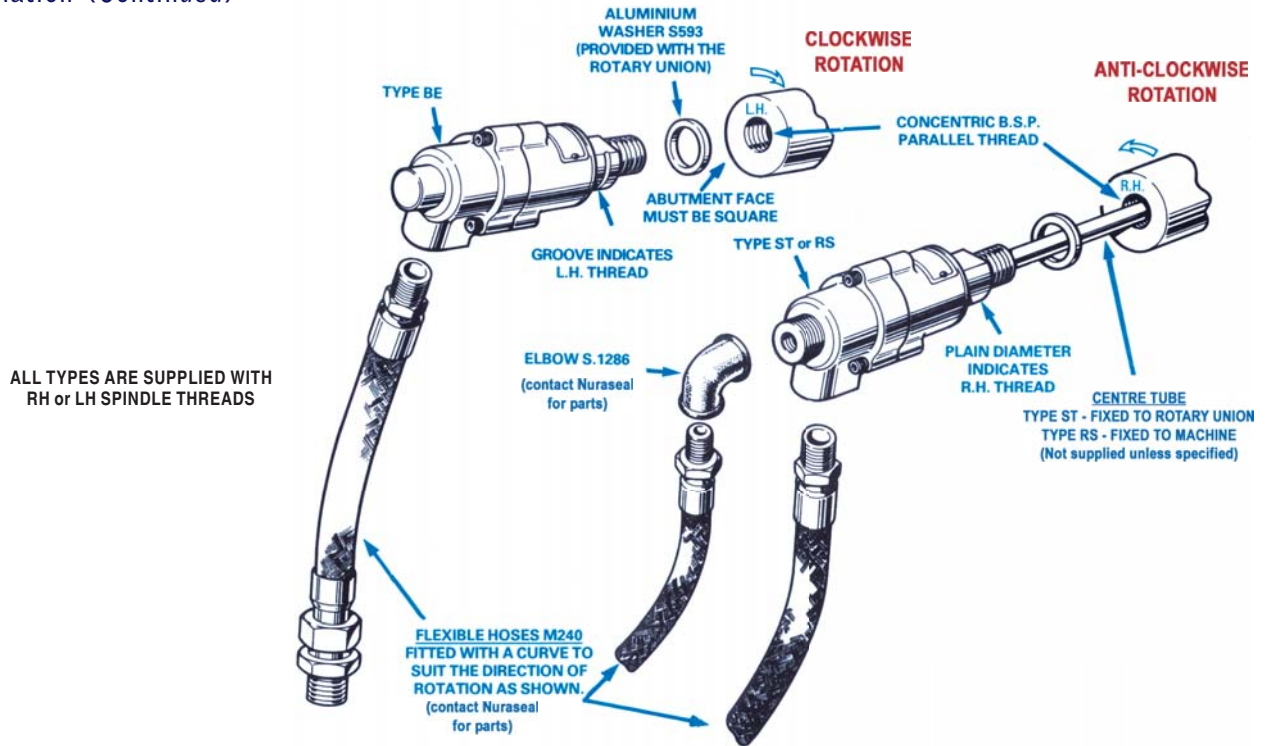

## Part Identification



Nominal Size	1	2	3	4	5 - Adapter			6	7	8	9	10	11
	Retainer	C/T Bearing	Screw	Bolt	B.E.	S.T.	R.S.	Seal Kit	R.E. Spacer	Circlip	Bearing Kit	R.E. Spindle (R.H. or L.H.)	R.E. Body
8 (1/4")	not used	17196/2 <sup>(v)</sup>	not used	3/16" BSF or M5	14642/1	14643/1	17196/1	S.1100/1	14636/6	M.184/2	S. 1234/1	14642/2	14636/2
10 (3/8")	not used	16265/9 <sup>(v)</sup>	not used	3/16" BSF or M5	14636/1	14637/1	17142/1	S.1100/1	14636/6	M.184/2	S. 1234/1	14636/3	14636/6
15 (1/2")	16657/3	16657/2	6 B.A.	1/4" BSF or M6	14536/1	14525/1	16657/1	S.1100/2	14534/3	M.184/3	S. 1234/2	14535/1	14534/1
20 (3/4")	16659/3	16659/2	6 B.A.	1/4" BSF or M6	14524/1	14523/1	16659/1	S.1100/2	14534/3	M.184/3	S. 1234/2	14534/2	14534/1
25 (1")	16661/3	16661/2	M3 x 0.5	5/16" BSF or M8	14396/1	14386/1	16661/1	S.1100/3	14396/3	M.184/4	S. 1234/3	14396/4	14396/2
32 (1-1/4")	16663/2	16663/3	M4 x 0.7	3/8" BSF or M10	14377/1	14488/1	16663/1	S.1100/4	14377/8	M.184/5	S. 1234/4	14377/3	14377/2

<sup>(v)</sup> Press Fit in Adapter.

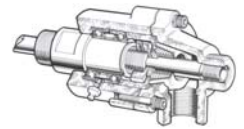

## Maintenance and Overhaul

- 1) Remove bolts and washers (4) which allow for the removal of the adapter (5) and body (11).
- 2) Remove the bellows subassembly and the gasket of the seal kit (6).
- 3) Remove locking screws and unscrew the carbon subassembly (R.H. thread) of the seal kit (6).
- 4) Remove the spacer (7).
- 5) Thoroughly clean and check the ball bearing kit (9). Re-lubricate using an approved grease. If there is any doubt about the bearing condition, replace it by removing circlip (8) and then pressing-off the bearing kit.
- 6) If the adapter (5) is Type R.S., remove the locking screw (3), unscrew the locking ring (1) and remove the C/T bearing (2).
- 7) Replace seal kit (6), bearing kit (9) and if Type R.S., C/T Bearing (2). Handle the seal kit with care to avoid damaging the lapped seal faces.
- 8) Thoroughly clean all parts before reassembly (which is virtually the reverse of the above steps).
- 9) After reassembly, follow the recommended installation procedures and allow for a suitable run-in period to ensure the seals are working correctly before refitting to the machine.

### Minimum Length for Flexible Hose

Nominal Size	Length (mm)	Part Number
8 (1/4")	150	M.240/1
10 (3/8")	230	M.240/2
15 (1/2")	305	M.240/3
20 (3/4")	305	M.240/4
25 (1")	380	M.240/5
32 (1-1/4")	460	M.240/6

## Lubrication

The bellows seal fitted to the rotary R.E. union is self-adjusting within its working life. The ball bearings are lubricated prior to shipping with a Bentone-base grease and occasionally require re-lubrication with a compatible grease; generally once per shift on "hot" applications and once per month on "cold" applications. For more specific recommendations, contact the grease manufacturer. Recommended lubricants include:

### BARDAHL

Multipurpose Grease #2 -20°C / +160°C  
Haute Temperature -10°C / +180°C

### BP

Energrease LS2 -30°C / +130°C  
Energrease HTG2 -20°C / +180°C

### BURMAH-CASTROL

Spheerol MP3 -40°C / +120°C  
Spheerol B2 -25°C / +180°C

### DOW CORNING

Molykote 44M -40°C / +180°C

### ELF OIL

Multi 2 -25°C / +130°C  
Staterma GB3 -10°C / +180°C

### ESSO

Beacon 2 -25°C / +125°C  
IL 2880 -20°C / +180°C

### KLÜBER

Centplex 2EP -20°C / +130°C  
Petamo GHY443 -25°C / +180°C

### MOBIL

Mobilplex 47 -25°C / +150°C  
Mobiltemp 1 +10°C / +180°C

### ROCOL LTD.

Sapphire 2 -30°C / +150°C  
Saphire Hi-Temp 2 -40°C / +180°C

### SHELL

Alvania EP LF2 -20°C / +120°C  
Darina Grease R2 +10°C / +190°C

### TEXACO

Multifak AFB2 -40°C / +120°C  
Starfak Ultratemp 2 -40°C / +175°C

\* **Note:** For subzero temperatures, please contact Nuraseal to ensure the model is suitable for the working conditions.

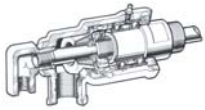

# ROTARY (P.B.) UNIONS

1/2" to 1"

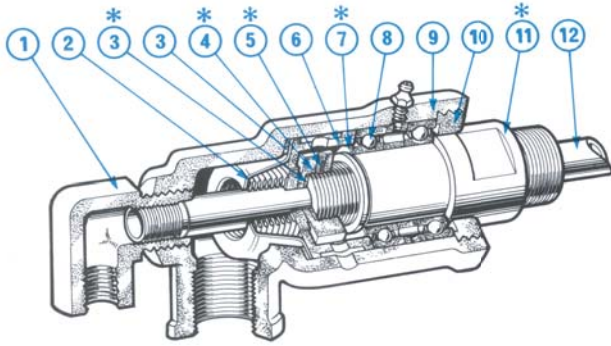

\* Note: The components indicated by ( \* ) rotate with the machine shaft.

## Rotary (P.B.) Union - Type S.T. (Bellows Seal)

1. Elbow, brass
2. Bellows sub-assembly, brazed stainless steel
3. Gaskets
4. Seal ring sub-assembly, steel/carbon
5. Locking screw, h.t. steel
6. Spacer
7. Circlip
8. Ball bearings
9. Body, dZR brass
10. Locking ring
11. Rotary Spindle, steel
12. Centre tube (if ordered)

Mechanical seals also available (add MS to the Part Number)

### Description

The rotary P.B. union has been developed from the rotary R.E. union and utilizes the same well-proven and highly successful bellows seal and bearing system. The body is manufactured from de-zincification resistant brass which has advantages over conventional brass and the cast iron adapter of the rotary R.E. union, especially for water cooling applications. There are three variations available (add MS to the part number to specify a mechanical seal):

#### 1) Type B.E. - Single Flow

A single flow union suitable for transferring fluid in to or out of rotating machines. The body is fitted with a plug at the outboard end which allows this type to be converted to a type S.T. or R.S. by using the appropriate elbow.

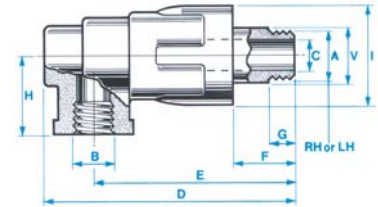

Type B.E.

#### 2) Type S.T. - Double Flow (Stationary Center Tube)

Fitted with an elbow suitable for double flow with a stationary center tube. This gives flow areas through the center tube and annulus. The center tube - provided only if ordered - is fixed to the union end by means of a screw thread (dimension "O"). Flow can pass in through the center tube and return through the annulus or be reversed. For steam applications, the center tube is curved to reach the condensate in the bottom of the cylinder. If the roll neck diameter to length ratio prevents the use of a curved tube, a syphon elbow can be specified instead. See the Accessory Section or contact us for more information about the options available.

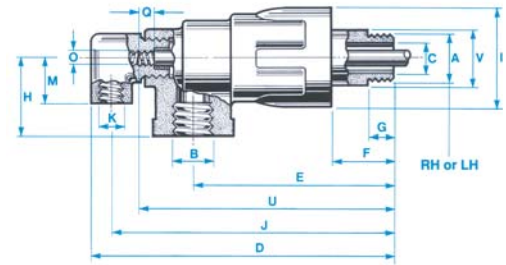

Type S.T.

#### 3) Type R.S. - Double Flow (Rotary Center Tube)

Fitted with an elbow suitable for a rotating center tube (which must be located and driven by the machine). The center tube - provided only if ordered - rotates in a labyrinth bush. Flow can pass in through the center tube and return through the annulus or be reversed. The center tube "sealing" system allows for a slight internal leakage between the supply and return lines. If these fluids must not mix, alternate designs are available. Please contact us for additional information.

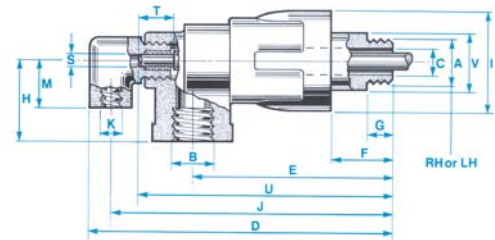

Type R.S.

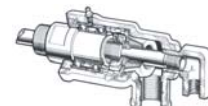

## Model and Dimensional Information

Nominal Size	Rotary (P.B.) Union Model Part Number <sup>(i)</sup>			Dimensions (mm unless specified otherwise)																				
				A <sup>(ii)</sup>	B	C	D		E	F	G	H	I	J	K	M	O	Q	S	T	U			V
	B.E. (R or L)	S.T. (R or L)	R.S. (R or L)				B.E.	S.T. / R.S.													B.E.	S.T.	R.S.	
15 (1/2")	18466	18467	18468	G. 1/2"	G. 1/2"	13	159	193	130	29	16	44	68	181	G. 1/4"	30	G. 1/8"	12	9.52 / 9.50	20	--	173	166	38
	18466U	18467U	18468U	3/4" - 16UNF	G. 1/2"	13	159	193	130	29	16	44	68	181	G. 1/4"	30	G. 1/8"	12	9.52 / 9.50	20	--	173	166	38
	18466MB	18467MB	18468MB	M22 x 1.5	G. 1/2"	13	159	193	130	29	16	44	68	181	G. 1/4"	30	G. 1/8"	12	9.52 / 9.50	20	--	173	166	38
20 (3/4")	18469	18470	18471	G. 3/4"	G. 3/4"	18	162	196	133	32	19	44	68	184	G. 1/4"	30	G. 1/4"	12	12.70 / 12.67	20	--	176	169	38
	18469U	18470U	18471U	1" - 14UNS	G. 3/4"	18	162	196	133	32	19	44	68	184	G. 1/4"	30	G. 1/4"	12	12.70 / 12.67	20	--	176	169	38
	18469MB	18470MB	18471MB	M30 x 1.5	G. 3/4"	18	162	196	133	32	19	44	68	184	G. 1/4"	30	G. 1/4"	12	12.70 / 12.67	20	--	176	169	38
25 (1")	18472	18473	18474	G. 1"	G. 1"	22	180	210	148	43	22	52	88	197	G. 3/8"	25	G. 3/8"	9.5	15.87 / 15.85	25	--	185	185	42
	18472U	18473U	18474U	1-1/2" - 12UNF	G. 1"	22	180	210	148	43	22	52	88	197	G. 3/8"	25	G. 3/8"	9.5	15.87 / 15.85	25	--	185	185	42
	18472MB	18473MB	18474MB	M35 x 1.5	G. 1"	22	180	210	148	43	22	52	88	197	G. 3/8"	25	G. 3/8"	9.5	15.87 / 15.85	25	--	185	185	42

- (i) Model part numbers shown are for units fitted with a bellows seal - add the suffix MS if mechanical seals are required.
- (ii) "G" is the designation for parallel pipe threads to BS.2779 and ISO 228/1.

## Flow Capacity

Nominal Size	Rotary (P.B.) Union - Model	Water <sup>(iii)</sup>		Steam <sup>(iv)</sup>	Air <sup>(v)</sup>
		m <sup>3</sup> /h	l/min	kg/h	m <sup>3</sup> /h
15 (1/2")	B.E.	1.7	28.3	61	58
	S.T. / R.S.	0.3	5	27	10
20 (3/4")	B.E.	2.7	45	101	96
	S.T. / R.S.	0.6	10	41	22
25 (1")	B.E.	4.1	68.3	151	144
	S.T. / R.S.	1.8	30	56	44

- (iii) Flow measured in cubic metres/hour at a velocity of 3 metres/second. (Also applies to other liquids.)
- (iv) Flow in kilograms/hour at a velocity of 30 metres/second and a pressure of 6 bar.
- (v) Flow in cubic metres/hour free air at a velocity of 15 metres/second and a pressure of 6 bar.

## Maximum Operating Recommendations

Fluids: Water, steam, mineral oils and compressed air (lubricated). All fluids should be clean and free from abrasive particles.

**\* Note:** It is not advisable to exceed or combine maximums.

Pressure: 17 bar maximum.

Vacuum: 740mm Hg. maximum (specify vacuum and we will test for this).

Temperature: -20°C to 160°C .

Speed: 1000 r.p.m. maximum with the bellows seal, 1500 r.p.m. maximum with the mechanical seal.

Storage: Store indoors in a dry area between the temperature ranges of -10°C to 30°C.

## Installation Requirements

- 1) A suitable run-in period before fitting is recommended. Rotate the P.B. at 300 r.p.m. for 15 minutes.
- 2) Add system liquid if seals squeak.
- 3) A torque arrestor may be fitted, but this must not restrict the rotary union.
- 4) Ensure that the spindle thread is RH or LH to suit the direction of rotation of the machine shaft.
- 5) If the machine shaft reverses direction of rotation, securely lock the spindle or (preferably) use a flanged connection.
- 6) DO NOT fix valves etc. directly on to the rotary union.
- 7) DO NOT connect with rigid pipe.
- 8) DO NOT clamp the rotary union.

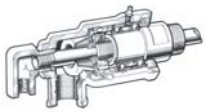

# ROTARY (P.B.) UNIONS

1/2" to 1"

## Installation (Continued)

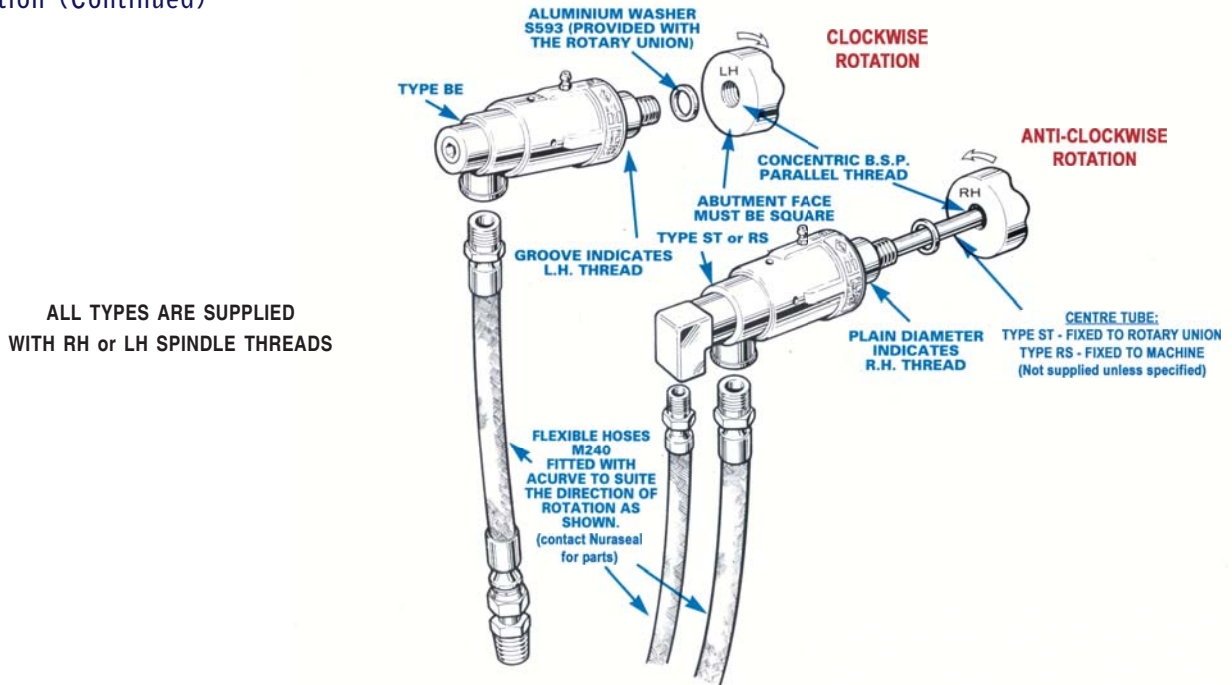

## Part Identification

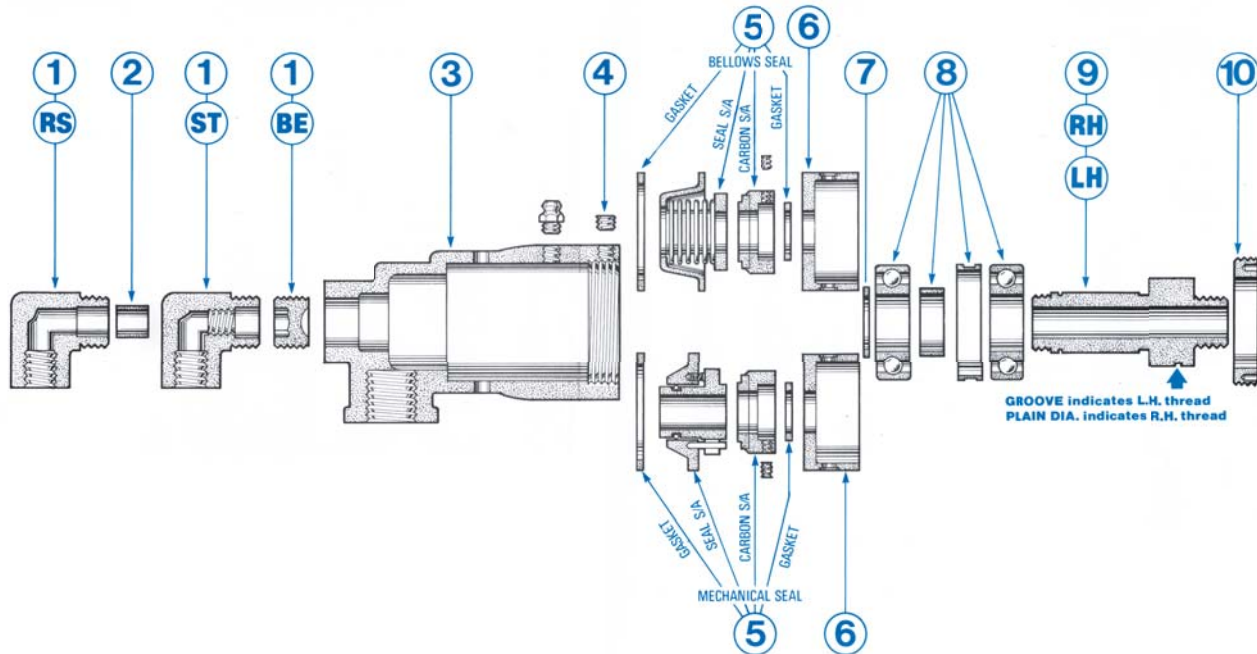

Nominal Size	Spindle Thread	1 - End Fitting			2 - C/T Bearing		3 - Body	4 - Locking Screw	5 - Seal Kit		6 - Spacer		7 - Circlip	8 - Bearing Kit	9 - Spindle	10 - Locking Ring
		B.E.	S.T.	R.S.	B.E. / S.T.	R.S.			Bellows	Mech.	Bellows	Mech.				
15 (1/2")	G. 1/2"	M244/4	18467/2	18468/1	--	14699/4	18467/1	M6 x 5	S1100/2	S1400/2	18467/2	15166/6A	M184/3	S1234/2	14535/1	18470/3
	3/4" - 16UNF	M244/4	18467/2	18468/1	--	14699/4	18467/1	M6 x 5	S1100/2	S1400/2	18467/2	15166/6A	M184/3	S1234/2	14535.U/1	18470/3
	M22 x 1.5	M244/4	18467/2	18468/1	--	14699/4	18467/1	M6 x 5	S1100/2	S1400/2	18467/2	15166/6A	M184/3	S1234/2	14535.M/1	18470/3
20 (3/4")	G. 3/4"	M244/4	18470/2	18471/1	--	14543/1	18470/1	M6 x 5	S1100/2	S1400/2	18467/2	15166/6A	M184/3	S1234/2	14534/2	18470/3
	1" - 14UNS	M244/4	18470/2	18471/1	--	14543/1	18470/1	M6 x 5	S1100/2	S1400/2	18467/2	15166/6A	M184/3	S1234/2	14534.U/2	18470/3
	M30 x 1.5	M244/4	18470/2	18471/1	--	14543/1	18470/1	M6 x 5	S1100/2	S1400/2	18467/2	15166/6A	M184/3	S1234/2	14535.M/2	18470/3
25 (1")	Please contact us for part number information on 25 (1").															

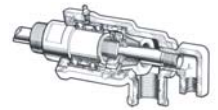

## Maintenance and Overhaul

- 1) Remove the locking screw (4) which allows for the removal of locking ring (10).
- 2) Remove the spindle (9) complete with bearing kit (8), circlip (7) and carbon subassembly of seal kit (5).
- 3) Remove spacer (6), seal subassembly and gasket of seal kit (5) from the body (3).
- 4) If type R.S., unscrew end fitting (1-R.S.) from the body, remove and replace the C/T Bearing (2).
- 5) Hold spindle (9) in a vice, remove locking screws to enable carbon subassembly of seal kit (5) to be unscrewed, then remove gasket.
- 6) Remove circlip (7) and press off bearing kit (8) from spindle (9).
- 7) Discard and replace seal kit (5) and bearing kit (8). Handle seal kits with care to avoid damaging the precision lapped seal faces.
- 8) Thoroughly clean all parts before reassembly (which is virtually the reverse of the above steps).
- 9) After reassembly, follow the recommended installation procedures and allow for a suitable run-in period to ensure the seals are working correctly before refitting to the machine.

### Minimum Length for Flexible Hose

Nominal Size	Length (mm)	Part Number
8 (1/4")	150	M.240/1
15 (1/2")	305	M.240/3
20 (3/4")	305	M.240/4

## Lubrication

The bellows seal or mechanical seal fitted to the rotary P.B. union is self-adjusting within its working life. The ball bearings are lubricated prior to shipping with a Bentone-base grease and occasionally require re-lubrication with a compatible grease; generally once per shift on "hot" applications and once per month on "cold" applications. For more specific recommendations, contact the grease manufacturer. Recommended lubricants include:

### ACHESON COLLOIDS COMPANY

Multilube Bearing Grease -25°C / +120°C  
Hi-Temp Bearing Grease -15°C / +160°C

### BARDAHL

Multipurpose Grease #2 -20°C / +160°C  
Haute Temperature -10°C / +180°C

### BP

Energrease LS2 -30°C / +130°C  
Energrease HTB2 -20°C / +180°C

### BURMAH-CASTROL

Spheerol AP3 -30°C / +110°C  
Spheerol BNS -25°C / +180°C

### CALTEX (UK) LTD.

Regal Starfak Premium 2 -40°C / +120°C  
RPM Indust. Grease Heavy -25°C / +165°C  
Thermatex EP -20°C / +180°C

### DOW CORNING

Molykote 44M -40°C / +180°C

### ELF OIL

Multi 2 -25°C / +130°C  
HTB 3 -25°C / +180°C

### ESSO

Beacon 2 -25°C / +125°C  
IL 2880 -20°C / +180°C

### MOBIL

Mobilplex 47 -25°C / +150°C  
Mobiltemp 1 +10°C / +180°C

### ROCOL LTD.

Sapphire -30°C / +150°C  
BG.442 -40°C / +180°C

### SHELL

Alvania RA -40°C / +145°C  
Darina Grease R2 +10°C / +190°C

### TEXACO

Multifak AFB2 -40°C / +120°C  
Starfak Ultratemp 2 -40°C / +175°C

**\* Note:** For subzero temperatures, please contact Nuraseal to ensure the model is suitable for the conditions.

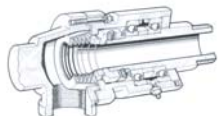

# ROTARY (R.E.B.) UNIONS

1-1/2" to 6"

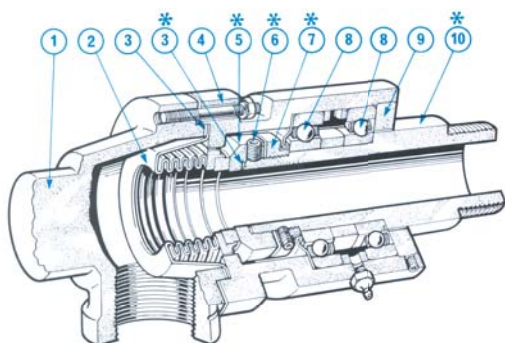

## Rotary (R.E.B.) Union - Type B.E.

1. Adaptor, s.g. iron
2. Bellows subassembly, brazed stainless steel / carbon
3. Gaskets
4. Body, s.g. iron
5. Seal ring, hardened stainless steel
6. Locking screws, h.t. steel
7. Locking ring - inner
8. Ball bearings - shielded from the seal chamber
9. Locking ring - outer
10. Rotary spindle, steel

\* **Note:** The components indicated by ( \* ) rotate with the machine shaft.

### Description

The rotary R.E.B. union is a self-contained, self-supporting rotary seal for the leak-proof transfer of fluids such as steam, water, air and oil to and from rotating machine shafts. The type of rotary seal fitted to this model is a Filton® Bellows Seal containing a flexible stainless steel bellows which is self-adjusting, eliminating the maintenance common with conventional packed glands. Rotary sealing is created by relative rotation between extremely flat sealing faces (see item #2 and #5 in diagram above) held in contact by the spring characteristics of the bellows combined with an additional sealing force created by the pressure of the fluid passing through the rotary union. The bearings fitted to the union are standard ball bearings which are supplied with the initial lubrication completed prior to shipping. A shield is fitted to the seal chamber side of the ball bearings. There are three variations of the stationary adapter end:

#### 1) Type B.E. - Single Flow

A single flow union suitable for transferring fluid in to or out of rotating machines.

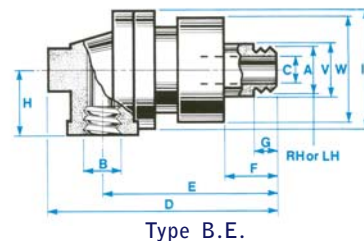

Type B.E.

#### 2) Type S.T. - Double Flow (Stationary Center Tube)

Fitted with an adapter suitable for double flow with a stationary center tube. This gives flow areas through the center tube and annulus. The center tube - provided only if ordered - is fixed to the union end by means of a screw thread (dimension "O"). Flow can pass in through the center tube and return through the annulus or be reversed. For steam applications, the center tube is curved to reach the condensate in the bottom of the cylinder. If the roll neck diameter to length ratio prevents the use of a curved tube, a syphon elbow can be specified instead. See the Accessory Section or contact us for more information about the options available.

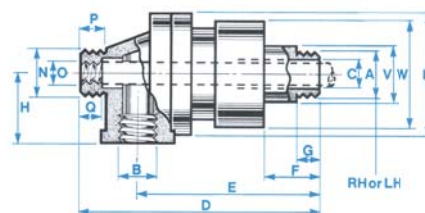

Type S.T.

#### 3) Type R.S. - Double Flow (Rotary Center Tube)

Fitted with an adapter suitable for a rotating center tube which must be located and driven by the machine. The center tube - provided only if ordered - rotates in a carbon bush. Flow can pass in through the center tube with the return through the annulus or be reversed. The center tube "sealing" system allows for a slight internal leakage between the supply and return lines. If these fluids must not mix, alternate designs are available. Please contact us for additional information.

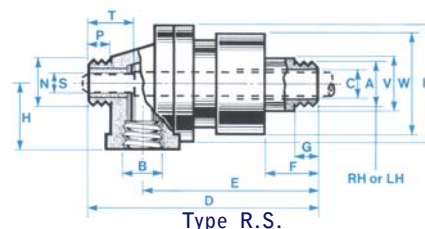

Type R.S.

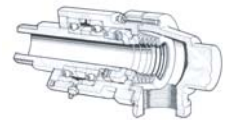

## Model and Dimensional Information

Nominal Size	Rotary (R.E.B.) Union - Model Part Number			Dimensions (mm unless specified otherwise)														
	B.E. (R or L)	S.T. (R or L)	R.S. (R or L)	A <sup>(i)</sup>	B, N	C	D	E	F	G, P	H	I	O	Q	S <sup>(ii)</sup>	T	V	W
40 (1-1/2")	18104	18105	18106	G. 1-1/2"	G. 1-1/2"	35	268	212	52	25	72	128	G. 3/4"	14	25.4, f8	50	64	108
50 (2")	17350	17238	17351	G. 2"	G. 2"	48	293	226	55	28	83	137	G. 1"	19	31.8, f8	60	76	127
65 (2-1/2")	18131	18132	18133	G. 2-1/2"	G. 2-1/2"	57	357	279	67	30	102	186	G. 1-1/4"	25	40, f8	55	90	150
80 (3")	17265	17266	17263	G. 3"	G. 3"	70	409	324	77	30	120	200	G. 1-1/2"	25	45, f8	70	110	180
90 (3-1/2")	17421	17422	17423	G. 3-1/2"	G. 4"	82	519	406	95	40	130	250	G. 2"	30	60, f8	60	140	240
100 (4")	17424	17425	17426	G. 4"	G. 4"	95	519	406	95	40	130	250	G. 2-1/2"	30	75, f8	60	140	240
125 (5")	17634.SF	17635.SF	17636.SF	Flanged <sup>(iii)</sup>	G. 5"	115	688	543	115	45	167	325	G. 3"	40	88, f8	70	192	290
150 (6")	17637.SF	17638.SF	17639.SF	Flanged <sup>(iii)</sup>	G. 6"	140	688	543	115	45	167	325	G. 3-1/2"	40	100, f8	70	192	290

(i) "G" is the designation for parallel pipe threads to BS.2779 and ISO 228/1.

(ii) The tolerance "f8" is to BS.EN 20286-2 and ISO 286-2.

(iii) Please contact us for more information about flanged dimensions.

## Flow Capacity

Nominal Size	Rotary (R.E.B.) Union - Model	Water <sup>(iv)</sup>		Steam <sup>(v)</sup>	Air <sup>(vi)</sup>	Nominal Size	Rotary (R.E.B.) Union - Model	Water <sup>(iv)</sup>		Steam <sup>(v)</sup>	Air <sup>(vi)</sup>
		m <sup>3</sup> /h	l/min	kg/h	m <sup>3</sup> /h			m <sup>3</sup> /h	l/min	kg/h	m <sup>3</sup> /h
40 (1-1/2")	B.E.	10.4	173	381	364	90 (3-1/2")	B.E.	57.0	950	2091	1996
	S.T. / R.S.	3.8	63	151	135		S.T. / R.S.	23.4	390	942	818
50 (2")	B.E.	19.5	325	717	684	100 (4")	B.E.	76.6	1277	2807	2679
	S.T. / R.S.	6.3	105	357	215		S.T. / R.S.	27.6	460	982	937
65 (2-1/2")	B.E.	30.5	508	1120	1069	125 (5")	B.E.	112.2	1870	4859	4639
	S.T. / R.S.	10.8	180	547	376		S.T. / R.S.	45.3	755	1617	1544
80 (3")	B.E.	41.6	693	1524	1455	150 (6")	B.E.	166.3	2772	6997	6680
	S.T. / R.S.	14.9	248	807	511		S.T. / R.S.	73.7	1228	2862	2760

(iv) Flow measured in cubic metres/hour at a velocity of 3 metres/second. (Also applies to other liquids.)

(v) Flow in kilograms/hour at a velocity of 30 metres/second and a pressure of 6 bar.

(vi) Flow in cubic metres/hour free air at a velocity of 15 metres/second and a pressure of 6 bar.

## Maximum Operating Recommendations

Fluids: Water, steam, mineral oils and compressed air (lubricated). All fluids should be clean and free from abrasive particles.

Pressure: 17 bar maximum.

Vacuum: 740mm Hg. maximum (specify vacuum and we will test for this).

Temperature: -20°C to 180°C (with suitable effective lubrication up to 200°C)  
-20°C to 120°C for sizes 125 (5") and 150 (6")

Speed: 600 r.p.m. maximum up to size 50 (2")  
500 r.p.m. for 65 (2-1/2") and 80 (3")  
400 r.p.m. for 90 (3-1/2") and 100 (4")  
300 r.p.m. for 125 (5") and 150 (6")

Storage: Store indoors in a dry area between the temperature ranges of -10°C to 30°C.

**\* Note:** It is not advisable to exceed or combine maximums.

## Installation Procedures

- 1) A suitable run-in period before fitting is recommended. Rotate the R.E.B. at 100 r.p.m. for 30 minutes for sizes ranging from 40 (1-1/2") to 80 (3"), and at 50 r.p.m. for 1 hour for all other sizes above.

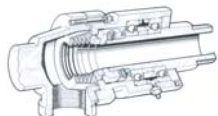

# ROTARY (R.E.B.) UNIONS

1-1/2" to 6"

## Installation Procedures (Continued)

- 2) Add system liquid if seals squeak.
- 3) A torque arrestor should be fitted, but this must not restrict the rotary union.
- 4) Ensure that the spindle thread is RH or LH to suit the direction of rotation of the machine shaft.
- 5) If the machine shaft reverses direction of rotation, securely lock the spindle or (preferably) use a flanged connection.
- 6) DO NOT fix valves etc. directly on to the rotary union.
- 7) DO NOT connect with rigid pipe.
- 8) DO NOT clamp the rotary union.

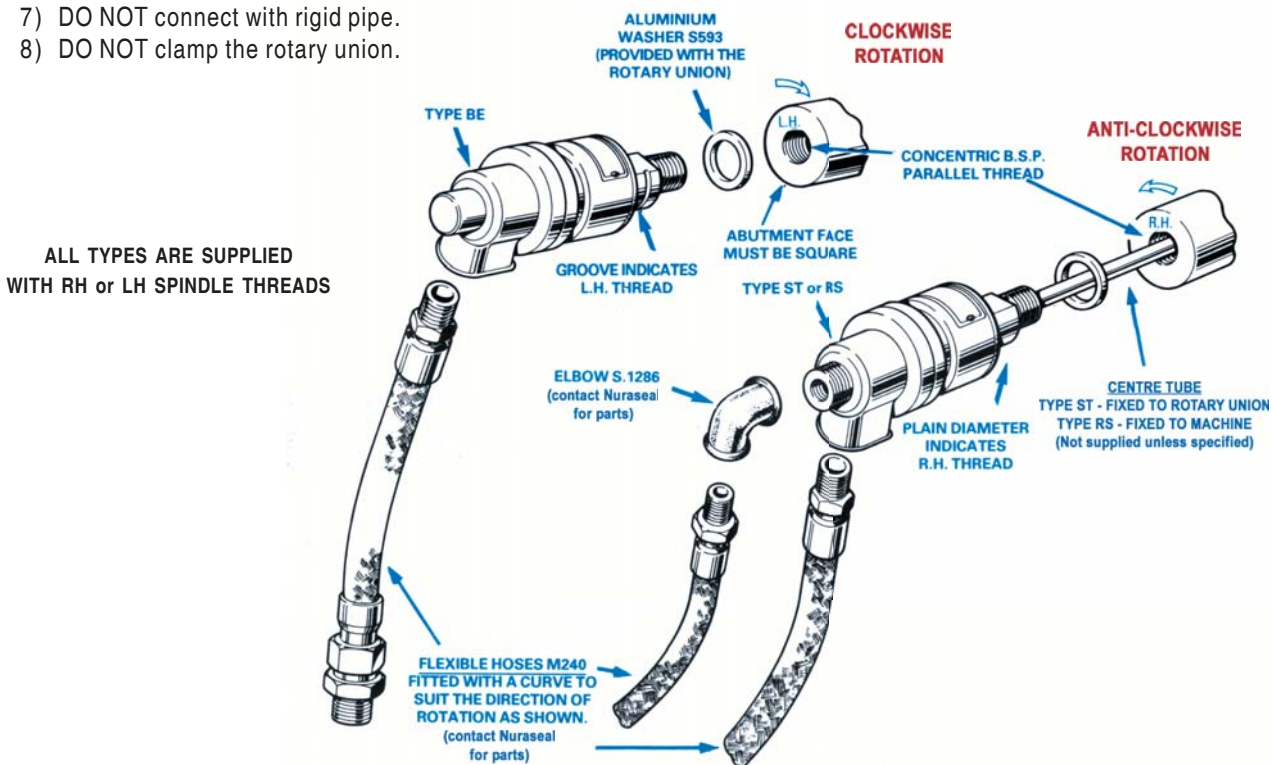

## Part Identification

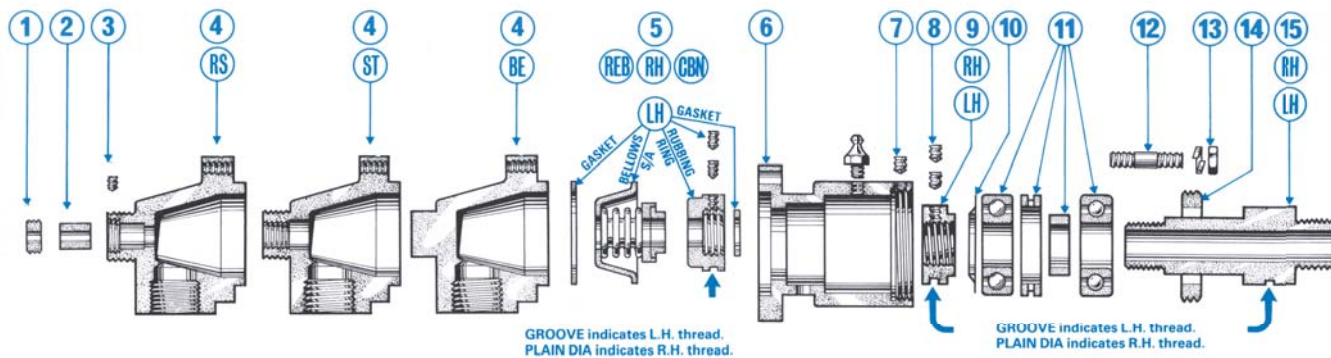

Nominal Size	1	2	3	4 - Adapter			5	6	7	8	9	10	11	12	13	14	15
	Retainer	C/T Bearing	Screw	R.S.	S.T.	B.E.	Seal Kit	Body	Screw	Screw	Locking Ring	Nilos Ring	Bearing Kit	Stud	Nut	Locking Ring	Spindle
40 (1-1/2")	18103/3	18103/2	M5 x 0.8	18103/1	18102/1	18101/1	S. 1151/3	18104/8	M6 x 1.0	M5 x 0.8	18104/4	18104/5	S. 1235/0	17238/4	M8 x 1.25	18104/2	18104/3
50 (2")	15473/1	15473/3	M5 x 0.8	15473/2	15472/1	15471/1	S. 1171/4	17238/11	M6 x 1.0	M4 x 0.7	17238/5	17238/12	S. 1235/1	17238/4	M8 x 1.25	17238/7	17238/8
65 (2-1/2")	15476/3	18133/2	M6 x 1.0	18133/1	18132/1	18131/1	S. 1171/8	18131/15	M6 x 1.0	M5 x 0.8	18131/10	18131/11	S. 1235/5	18131/6	M10 x 1.5	18131/13	18131/14
80 (3")	15479/3	15479/2	M6 x 1.0	15479/1	15478/1	15477/1	S. 1171/5	17263/11	M6 x 1.0	M5 x 0.8	17263/5	17263/16	S. 1235/2	17423/1	M12 x 1.75	17263/7	17263/8
90 (3-1/2")	16173/3	16173/2	M6 x 1.0	16173/1	16172/1	16171/1	S. 1151/6	17423/7	M5 x 0.8	M5 x 0.8	17423/2	17155/15	S. 1235/3	17423/1	M12 x 1.75	17423/8	17423/9
100 (4")	16176/3	16176/2	M6 x 1.0	16176/1	16175/1	16174/1	S. 1151/6	17423/7	M5 x 0.8	M5 x 0.8	17423/2	17155/15	S. 1235/3	17423/1	M12 x 1.75	17423/8	17426/1
125 (5")	15488/3	15488/2	M8 x 1.25	15488/1	15487/1	15486/1	S. 1151/7	17635/3	M12 x 1.75	M12 x 7.5	17635/5	17635/4	S. 1235/4	17635/7	M16 x 2	17635/2	17635/1
150 (6")	16702/1	16702/3	M8 x 1.25	16702/1	16703/2	16704/1	S. 1151/7	17635/3	M12 x 1.75	M12 x 7.5	17635/5	17635/4	S. 1235/4	17635/7	M16 x 2	17635/2	17637/1

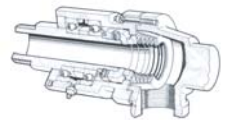

## Maintenance and Overhaul

- 1) Remove nuts (13) and washers which allows for the removal of adaptor (4).
- 2) Remove bellows subassembly and gasket of seal kit (5).
- 3) Remove locking screw (7) and unscrew locking ring (14 - RH Thread) and extract spindle (15) complete with ball bearings, etc.
- 4) Remove locking screws from the rubbing ring of seal kit (5), unscrew the rubbing ring (RH or LH thread) and remove gasket.
- 5) Thoroughly clean the ball bearing kit (11), check the condition of the bearings and re-grease. If there is any doubt about the condition, replace the bearing kit and pre-pack with an approved grease.
- 6) To replace the bearing kit (11), remove locking screws (8), bearing locking ring (9 - RH or LH Thread) and Nilos ring (10). Press off the bearing kit.
- 7) If the adaptor (4) is Type R.S., remove locking screw (3), unscrew locking ring (1 - RH Thread) and remove C/T bearing (2).
- 8) Replace seal kit (5), bearing kit (11) and if type RS, C/T bearing (2). Handle seal kits with care to avoid damaging the precision lapped seal faces.
- 9) Thoroughly clean all parts before reassembly (which is virtually the reverse of the above steps).
- 10) After reassembly, follow the recommended installation procedures and allow for a suitable run-in period to ensure the seals are working correctly before refitting to the machine.

### Minimum Length for Flexible Hose

Nominal Size	Length (mm)	Part Number
40 (1-1/2")	460	M.240/7
50 (2")	610	M.240/8
65 (2-1/2")	610	M.240/9
80 (3")	760	M.240/10
90 (3-1/2")	760	M.240/10
100 (4")	915	M.240/11
125 (5")	915	M.240/12
150 (6")	915	M.240/13

**\* Note:** For the 125 (5") and 150 (6") models, there is a screwed adjusting ring on the flanged end of the body which is locked with a screw and can be adjusted to give 6mm compression on the bellows subassembly if necessary.

## Lubrication

The bellows seal fitted to the rotary R.E.B. union is self-adjusting within its working life. The ball bearings are lubricated prior to shipping with a Bentone-base grease and occasionally require re-lubrication with a compatible grease; generally once per shift on "hot" applications and once per month on "cold" applications. For more specific recommendations, contact the grease manufacturer. Recommended lubricants include:

### ACHESON COLLOIDS COMPANY

Multilube Bearing Grease -25°C / +120°C  
Hi-Temp Bearing Grease -15°C / +160°C

### BARDAHL

Multipurpose Grease #2 -20°C / +160°C  
Haute Temperature -10°C / +180°C

### BP

Energrease LS2 -30°C / +130°C  
Energrease HTB2 -20°C / +180°C

### BURMAH-CASTROL

Spherol AP3 -30°C / +110°C  
Spherol BNS -25°C / +180°C

### CALTEX (UK) LTD.

Regal Starfak Premium 2 -40°C / +120°C  
RPM Ind. Grease Heavy -25°C / +165°C  
Thermatex EP -20°C / +180°C

### DOW CORNING

Molykote 44M -40°C / +180°C

### ELF OIL

Multi 2 -25°C / +130°C  
HTB 3 -25°C / +180°C

### ESSO

Beacon 2 -25°C / +125°C  
IL 2880 -20°C / +180°C

### MOBIL

Mobilplex 47 -25°C / +150°C  
Mobiltemp 1 +10°C / +180°C

### PETROFINA (UK) LTD.

Marson L2 -20°C / +120°C  
Bentex A3 -20°C / +190°C

### ROCOL LTD.

Sapphire -30°C / +150°C  
BG.442 -40°C / +180°C

### SHELL

Alvania RA -40°C / +145°C  
Darina Grease R2 +10°C / +190°C

### TEXACO

Multifak AFB2 -40°C / +120°C  
Starfak Ultratemp 2 -40°C / +175°C

**\* Note:** For subzero temperatures, please contact Nuraseal to ensure the model is suitable for the conditions.

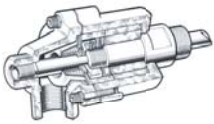

# ROTARY (C.B.) UNIONS

High Temperature  
1/4" to 1-1/4"

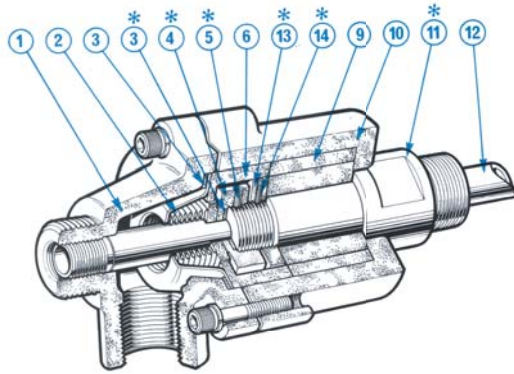

\* **Note:** The components indicated by ( \* ) rotate with the machine shaft.

## Rotary (C.B.) Union - Type S.T.

1. Adaptor, high quality cast-iron
2. Bellows subassembly, brazed stainless steel
3. Gaskets
4. Seal ring subassembly, steel / carbon
5. Locking screw, heat treated steel
6. Spacer
9. Bearing subassembly, steel / carbon
10. Body - high quality cast iron
11. Rotary spindle, steel
12. Centre tube (if ordered)
13. Thrust pad, stainless steel
14. Set screw, heat treated steel

### Description

The rotary C.B. union is a self-contained, self-supporting rotary seal for the leak-proof transfer of fluids such as steam, water, air and oil to and from rotating machine shafts. The type of rotary seal fitted to this model is a Filton® Bellows Seal containing a flexible stainless steel bellows which is self-adjusting, eliminating the maintenance common with conventional packed glands. Rotary sealing is created by relative rotation between extremely flat sealing faces (see item #2 and #4 in diagram above) held in contact by the spring characteristics of the bellows combined with an additional sealing force created by the pressure of the fluid passing through the rotary union. The bearing fitted to the union is a cylindrical carbon combined journal and thrust bearing in which a hard chromed and ground spindle rotates. There are three variations of the stationary adapter end:

#### 1) Type B.E. - Single Flow

A single flow union suitable for transferring fluid in to or out of rotating machines.

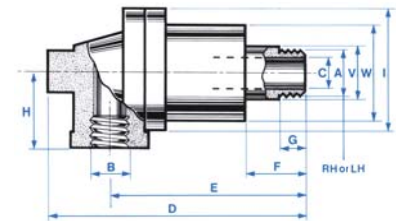

Type B.E.

#### 2) Type S.T. - Double Flow (Stationary Center Tube)

Fitted with an adapter suitable for double flow with a stationary center tube. This gives flow areas through the center tube and annulus. The center tube - provided only if ordered - is fixed to the union end by means of a screw thread (dimension "O"). Flow can pass in through the center tube and return through the annulus or be reversed. For steam applications, the center tube is curved to reach the condensate in the bottom of the cylinder. If the roll neck diameter to length ratio prevents the use of a curved tube, a syphon elbow can be specified instead. See the Accessory Section or contact us for more information about the options available.

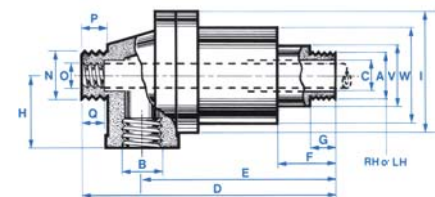

Type S.T.

#### 3) Type R.S. - Double Flow (Rotary Center Tube)

Fitted with an adapter suitable for a rotating center tube which must be located and driven by the machine. The center tube - provided only if ordered - rotates in a bush. Flow can pass in through the center tube with the return through the annulus or be reversed. The center tube "sealing" system allows for a slight internal leakage between the supply and return lines. If these fluids must not mix, alternate designs are available. Please contact us for additional information.

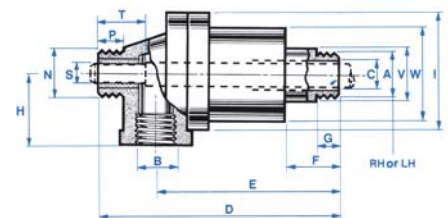

Type R.S.

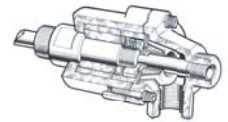

### Model and Dimensional Information

Nominal Size	Rotary (C.B.) Union - Model Part Number			Dimensions (mm unless specified otherwise)													
	B.E. (R or L)	S.T. (R or L)	R.S. (R or L)	A, B, N <sup>(i)</sup>	C	D	E	F	G, P	H	I	O	Q	S	T	V	W
8 (1/4")	14645	14646M	17215	G. 1/4"	6	117	94	22	11	30	57	M5 x 0.8	6	4.75 / 4.72	25	24	44
10 (3/8")	14639	14640M	17216	G. 3/8"	10	121	97	25	13	30	57	M6 x 1.0	6	6.35 / 6.32	25	24	44
15 (1/2")	14554	14525	16658	G. 1/2"	13	167	130	29	16	44	83	G. 1/8"	6	9.52 / 9.50	40	38	63
20 (3/4")	14524	14523	16660	G. 3/4"	18	173	133	32	19	44	83	G. 1/4"	10	12.70 / 12.67	40	38	63
25 (1")	14545	14386	16662	G. 1"	22	210	162	48	22	54	105	G. 3/8"	10	15.87 / 15.85	45	43	83
32 (1-1/4")	14546	14488	16664	G. 1-1/4"	30	238	181	51	25	70	121	G. 1/2"	13	19.05 / 19.02	50	55	95

(i) "G" is the designation for parallel pipe threads to BS.2779 and ISO 228/1.

### Flow Capacity

Nominal Size	Rotary (C.B.) Union - Model	Water <sup>(ii)</sup>		Steam <sup>(iii)</sup>	Air <sup>(iv)</sup>
		m <sup>3</sup> /h	l/min	kg/h	m <sup>3</sup> /h
8 (1/4")	B.E.	0.3	5.0	11	11
	S.T. / R.S.	0.05	0.8	3.4	2
10 (3/8")	B.E.	0.8	13.3	31	29
	S.T. / R.S.	0.1	1.7	16	4
15 (1/2")	B.E.	1.7	28.3	61	58
	S.T. / R.S.	0.3	5	27	10
20 (3/4")	B.E.	2.7	45	101	96
	S.T. / R.S.	0.6	10	41	22
25 (1")	B.E.	4.1	68.3	151	144
	S.T. / R.S.	1.8	30	56	44
32 (1-1/4")	B.E.	7.6	127	280	267
	S.T. / R.S.	2.1	35	133	74

(ii) Flow measured in cubic metres/hour at a velocity of 3 metres/second. (Also applies to other liquids.)

(iii) Flow in kilograms/hour at a velocity of 30 metres/second and a pressure of 6 bar.

(iv) Flow in cubic metres/hour free air at a velocity of 15 metres/second and a pressure of 6 bar.

### Maximum Operating Recommendations

Fluids: Water, steam, mineral oils and compressed air (lubricated). All fluids should be clean and free from abrasive particles.

Pressure: 17 bar maximum.

Temperature: 100°C to 300°C (lower temperatures dependant on other conditions - please contact us for details).

Speed: 500 r.p.m. maximum up to size 25 (1") and 400 r.p.m. for 32 (1-1/4").

Storage: Store indoors in a dry area between the temperature ranges of -10°C to 30°C.

\* **Note:** It is not advisable to exceed or combine maximums.

### Installation Procedures

- 1) A suitable run-in period before fitting is recommended. Rotate the C.B. at 150 r.p.m. for 30 minutes.
- 2) Add system liquid if seals squeak.
- 3) A torque arrestor may be fitted, but this must not restrict the rotary union.
- 4) Ensure that the spindle thread is RH or LH to suit the direction of rotation of the machine shaft.
- 5) If the machine shaft reverses direction of rotation, securely lock the spindle or (preferably) use a flanged connection.
- 6) DO NOT fix valves etc. directly on to the rotary union.
- 7) DO NOT connect with rigid pipe.
- 8) DO NOT clamp the rotary union.

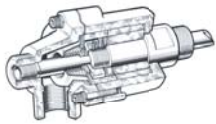

# ROTARY (C.B.) UNIONS

High Temperature  
1/4" to 1-1/4"

## Installation (Continued)

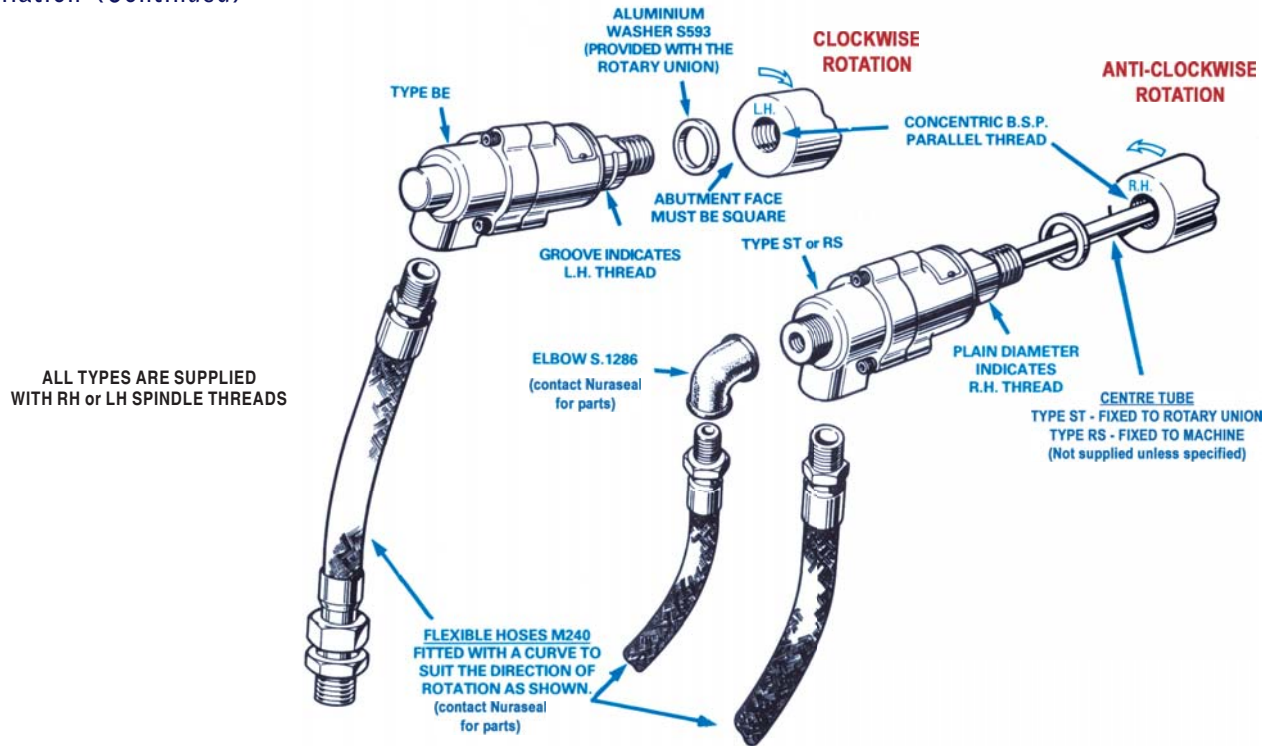

## Part Identification

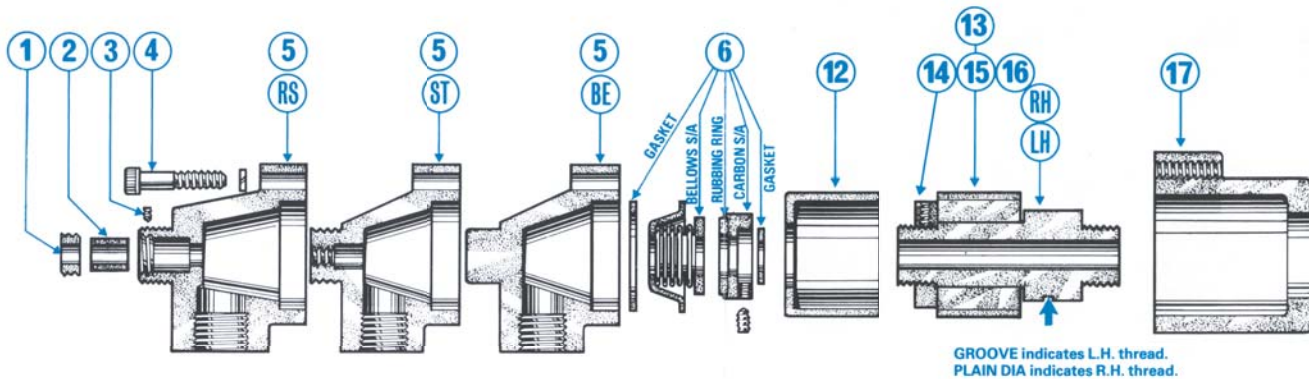

Nominal Size	1	2	3	4	5 - Adapter			6	12	13	14	15	16	17
	Retainer	C/T Bearing	Screw	Bolt	B.E.	S.T.	R.S.	Seal Kit	C.B. Spacer	Spindle S/A	Thrust Pad	Bearing	C.B. Spindle (RH or LH)	C.B. Body
8 (1/4")	not used	17196/2 <sup>(v)</sup>	not used	3/16" BSF or M5	14642/1	14643/1	17196/1	S.1100/1	14639/3	14645/2	14639/4	14639/7	14645/1	14639/2
10 (3/8")	not used	16265/9 <sup>(v)</sup>	not used	3/16" BSF or M5	14636/1	14637/1	17142/1	S.1100/1	14639/3	14639/8	14639/4	14639/7	14639/1	14639/2
15 (1/2")	16657/3	16657/2	6 B.A.	1/4" BSF or M6	14536/1	14525/1	16657/1	S.1100/2	14397/8	14525/3	14397/9	14397/20	14525/2	14397/2
20 (3/4")	16659/3	16659/2	6 B.A.	1/4" BSF or M6	14524/1	14523/1	16659/1	S.1100/2	14397/8	14397/25	14397/9	14397/20	14397/13	14397/2
25 (1")	16661/3	16661/2	M3 x 0.5	5/16" BSF or M8	14396/1	14386/1	16661/1	S.1100/3	14386/12	14386/21	14386/7	14386/17	14386/11	14386/2
32 (1-1/4")	16663/2	16663/3	M4 x 0.7	3/8" BSF or M10	14377/1	14488/1	16663/1	S.1100/4	14398/5	14398/18	14398/6	14398/14	14398/10	14398/2

<sup>(v)</sup> Press Fit in Adapter.

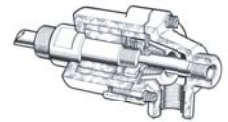

### Maintenance and Overhaul

- 1) Remove bolts and washers (4) which allow for removal of the adapter (5) and body (17).
- 2) Remove the bellows subassembly and the gasket of the seal kit (6).
- 3) Remove locking screws and unscrew the carbon subassembly (RH thread) of the seal kit (6).
- 4) Remove the spacer (12).
- 5) If the spindle subassembly (13) is in poor condition i.e. there is considerable wear is evident on the bearing, discard and replace.
- 6) If the condition of the spindle subassembly (13) appears reasonable, it can be dismantled by removing all locking screws and unscrewing the thrust ring (14 - RH Thread). The bearing subassembly (15) can now be removed and should be replaced.
- 7) The spindle (16) should be examined on the hard chromed bearing diameter and, if wear of more than 0.05 mm has occurred on the hardened surfaces, it should be discarded and the entire spindle subassembly (13) should be replaced.
- 8) If the adapter (5) is Type R.S., remove locking screw (3), unscrew locking ring (1 - RH Thread) and remove the C/T Bearing (2).
- 9) Replace seal kit (6), spindle subassembly (13 - see Step #6) and if Type R.S., the C/T Bearing (2). Handle the seal kit with care to avoid damaging the lapped seal faces.
- 10) Thoroughly clean all parts before reassembly (which is virtually the reverse of the above steps).
- 11) After reassembly, follow the recommended installation procedures and allow for a suitable run-in period to ensure the seals are working correctly before refitting to the machine.

#### Minimum Length for Flexible Hose

Nominal Size	Length (mm)	Part Number
8 (1/4")	150	M.240/1
10 (3/8")	230	M.240/2
15 (1/2")	305	M.240/3
20 (3/4")	305	M.240/4
25 (1")	380	M.240/5
32 (1-1/4")	460	M.240/6

### Lubrication

The bellows seal fitted to the Rotary C.B. Union is self-adjusting within its working life. The union has dry carbon journal and thrust bearings operating on hardened surfaces. **DO NOT GREASE.** We advise periodic inspection for bearing wear.

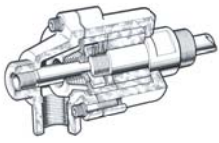

# ROTARY (C.B.N.) UNIONS

High Temperature  
1-1/2" to 6"

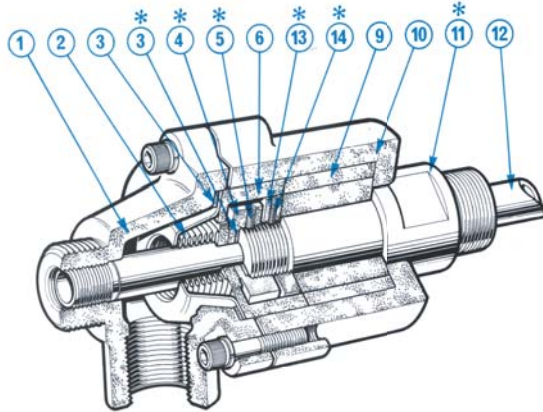

\* Note: The components indicated by ( \* ) rotate with the machine shaft.

## Rotary (C.B.N.) Union - Type B.E.

1. Adaptor, s.g. iron
2. Bellows subassembly, brazed stainless steel / carbon
3. Gaskets
4. Spacer, plated steel
5. Seal ring, hardened stainless steel
6. Locking screws, h.t. steel
7. Thrust bearing, carbon
8. Journal bearing, carbon
9. Body, s.g. iron
10. Rotary spindle, steel

### Description

The rotary C.B.N. union is a self-contained, self-supporting rotary seal for the leak-proof transfer of fluids such as steam, water, air and oil to and from rotating machine shafts. The type of rotary seal fitted to this model is a Filton® Bellows Seal containing a flexible stainless steel bellows which is self-adjusting, eliminating the maintenance common with conventional packed glands. Rotary sealing is created by relative rotation between extremely flat sealing faces (see item #2 and #5 in diagram above) held in contact by the spring characteristics of the bellows combined with an additional sealing force created by the pressure of the fluid passing through the rotary union. The bearings fitted to the union are separate carbon thrust and journal bearings in which a hard chromed and ground spindle rotates. There are three variations of the stationary adapter end:

#### 1) Type B.E. - Single Flow

A single flow union suitable for transferring fluid in to or out of rotating machines.

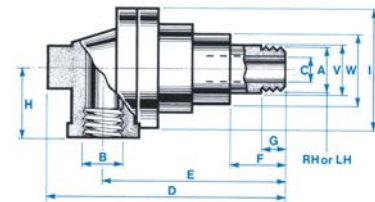

Type B.E.

#### 2) Type S.T. - Double Flow (Stationary Center Tube)

Fitted with an adapter suitable for double flow with a stationary center tube. This gives flow areas through the center tube and annulus. The center tube - provided only if ordered - is fixed to the union end by means of a screw thread (dimension "O"). Flow can pass in through the center tube and return through the annulus or be reversed. For steam applications, the center tube is curved to reach the condensate in the bottom of the cylinder. If the roll neck diameter to length ratio prevents the use of a curved tube, a syphon elbow can be specified instead. See the Accessory Section or contact us for more information about the options available.

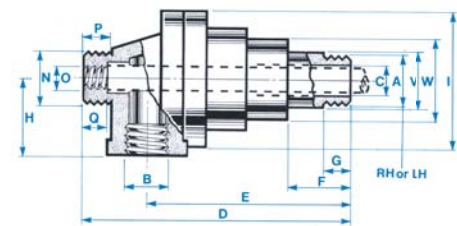

Type S.T.

#### 3) Type R.S. - Double Flow (Rotary Center Tube)

Fitted with an adapter suitable for a rotating center tube which must be located and driven by the machine. The center tube - provided only if ordered - rotates in a carbon bush. Flow can pass in through the center tube with the return through the annulus or be reversed. The center tube "sealing" system allows for a slight internal leakage between the supply and return lines. If these fluids must not mix, alternate designs are available. Please contact us for additional information.

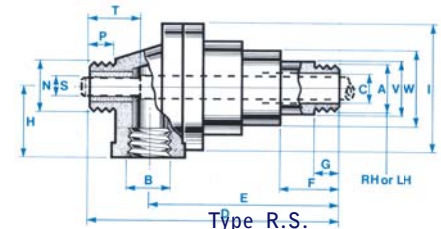

Type R.S.

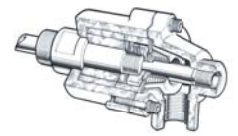

Model and Dimensional Information

Nominal Size	Rotary (C.B.N.) Union - Model Part Number			Dimensions (mm unless specified otherwise)														
	B.E. (R or L)	S.T. (R or L)	R.S. (R or L)	A <sup>(i)</sup>	B, N	C	D	E	F	G, P	H	I	O	Q	S <sup>(ii)</sup>	T	V	W
40 (1-1/2")	18101	18102	18103	G. 1-1/2"	G. 1-1/2"	35	263	207	56	25	72	128	G. 3/4"	14	25.4, f8	50	64	78
50 (2")	15471	15472	15473	G. 2"	G. 2"	48	293	226	64	28	83	137	G. 1"	19	31.8, f8	60	76	94
65 (2-1/2")	18240	18241	18242	G. 2-1/2"	G. 2-1/2"	57	356	278	75	30	102	186	G. 1-1/4"	25	40, f8	55	90	112
80 (3")	15477	15478	15479	G. 3"	G. 3"	70	407	323	80	30	120	200	G. 1-1/2"	25	45, f8	70	110	130
90 (3-1/2")	16171	16172	16173	G. 3-1/2"	G. 4"	82	518	405	110	40	130	250	G. 2"	30	60, f8	60	140	160
100 (4")	16174	16175	16176	G. 4"	G. 4"	95	518	405	110	40	130	250	G. 2-1/2"	30	75, f8	60	140	160
125 (5")	15468.SF	15487.SF	15488.SF	Flanged <sup>(iii)</sup>	G. 5"	115	688	513	115	45	167	325	G. 3"	40	88, f8	70	192	220
150 (6")	16704.SF	16703.SF	16702.SF	Flanged <sup>(iii)</sup>	G. 6"	140	688	513	115	45	167	325	G. 3-1/2"	40	100, f8	70	192	220

- (i) "G" is the designation for parallel pipe threads to BS.2779 and ISO 228/1.
- (ii) The tolerance "f8" is to BS.EN 20286-2 and ISO 286-2.
- (iii) Please contact us for more information about flanged dimensions.

Flow Capacity

Nominal Size	Rotary (C.B.N.) Union - Model	Water <sup>(iv)</sup>		Steam <sup>(v)</sup>	Air <sup>(vi)</sup>	Nominal Size	Rotary (C.B.N.) Union - Model	Water <sup>(iv)</sup>		Steam <sup>(v)</sup>	Air <sup>(vi)</sup>
		m <sup>3</sup> /h	l/min	kg/h	m <sup>3</sup> /h			m <sup>3</sup> /h	l/min	kg/h	m <sup>3</sup> /h
40 (1-1/2")	B.E.	10.4	173	381	364	90 (3-1/2")	B.E.	57.0	950	2091	1996
	S.T. / R.S.	3.8	63	151	135		S.T. / R.S.	23.4	390	942	818
50 (2")	B.E.	19.5	325	717	684	100 (4")	B.E.	76.6	1277	2807	2679
	S.T. / R.S.	6.3	105	357	215		S.T. / R.S.	27.6	460	982	937
65 (2-1/2")	B.E.	30.5	508	1120	1069	125 (5")	B.E.	112.2	1870	4859	4639
	S.T. / R.S.	10.8	180	547	376		S.T. / R.S.	45.3	755	1617	1544
80 (3")	B.E.	41.6	693	1524	1455	150 (6")	B.E.	166.3	2772	6997	6680
	S.T. / R.S.	14.9	248	807	511		S.T. / R.S.	73.7	1228	2862	2760

- (iv) Flow measured in cubic metres/hour at a velocity of 3 metres/second. (Also applies to other liquids.)
- (v) Flow in kilograms/hour at a velocity of 30 metres/second and a pressure of 6 bar.
- (vi) Flow in cubic metres/hour free air at a velocity of 15 metres/second and a pressure of 6 bar.

Maximum Operating Recommendations

Fluids: Water, steam, mineral oils and compressed air (lubricated). All fluids should be clean and free from abrasive particles.

Pressure: 17 bar maximum.

Temperature: 100°C to 300°C (lower temperatures dependant on other conditions)

Speed: 300 r.p.m. maximum up to size 50 (2")  
 250 r.p.m. for 65 (2-1/2") and 80 (3")  
 200 r.p.m. for 90 (3-1/2") and 100 (4")  
 150 r.p.m. for 125 (5") and 150 (6")

Storage: Store indoors in a dry area between the temperatures ranges of -10°C to 30°C.

\* Note: It is not advisable to exceed or combine maximums.

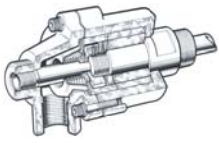

# ROTARY (C.B.N.) UNIONS

High Temperature  
1-1/2" to 6"

## Installation Procedures

- 1) A suitable run-in period before fitting is recommended. Rotate the C.B.N. at 50 r.p.m. for 1 hour for sizes ranging from 40 (1-1/2") to 80 (3") and at 25 r.p.m. for 2 hours for all other sizes above.
- 2) Add system liquid if seals squeak.
- 3) A torque arrestor should be fitted, but this must not restrict the rotary union.
- 4) Ensure that the spindle thread is RH or LH to suit the direction of rotation of the machine shaft.
- 5) If the machine shaft reverses direction of rotation, securely lock the spindle or (preferably) use a flanged connection.
- 6) DO NOT fix valves etc. directly on to the rotary union.
- 7) DO NOT connect with rigid pipe.
- 8) DO NOT clamp the rotary union.

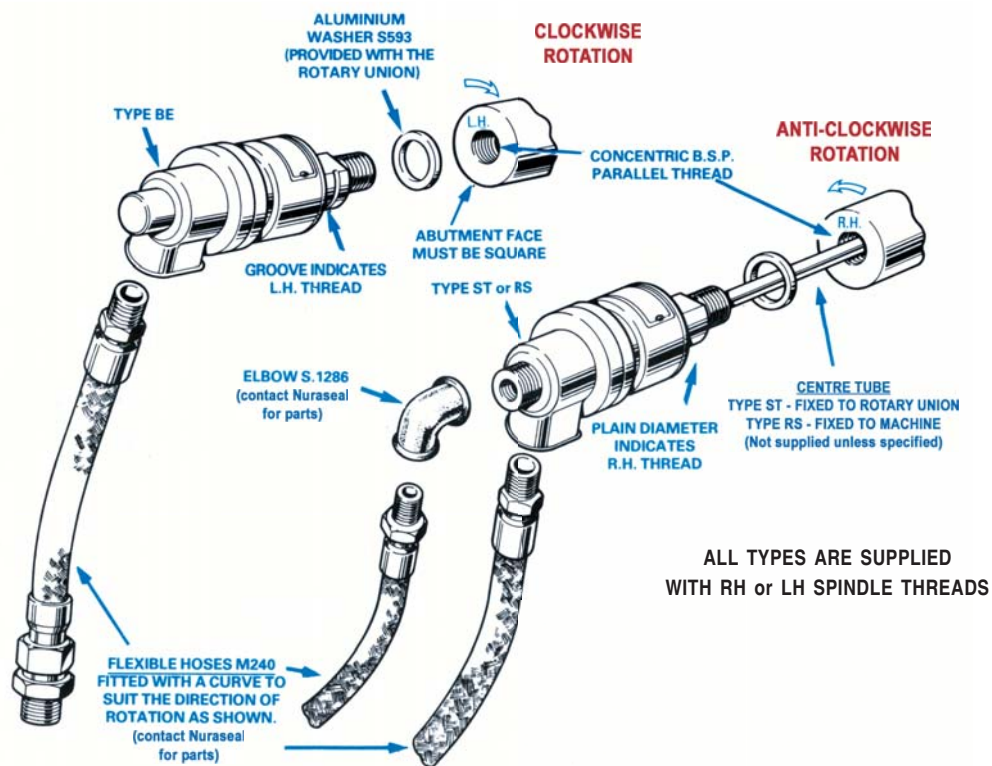

## Part Identification

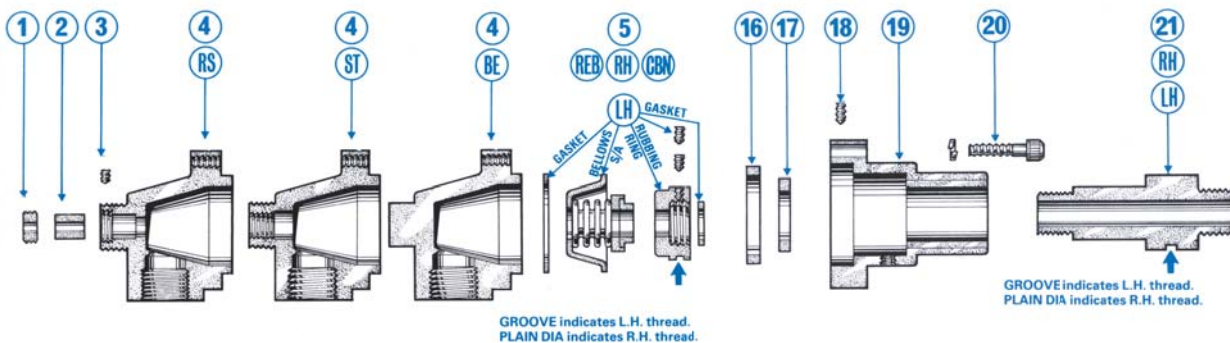

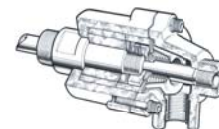

Part Identification (Continued)

Nominal Size	1	2	3	4 - Adapter			5	16	17	18	19	20	21
	Retainer	C/T Bearing	Screw	B.E.	S.T.	R.S.	Seal Kit	Spacer	Thrust Pad	Screw	Body S/A	Bolt	Spindle
40 (1-1/2")	18103/3	18103/2	M5 x 0.8	18103/1	18102/1	18101/1	S. 1151/3	18101/10	18101/5	N/A	18101/12	M8 x 1.25	18101/8
50 (2")	15473/1	15473/3	M5 x 0.8	15473/2	15472/1	15471/1	S. 1151/4	15325/7	15325/11	N/A	15325/15	M8 x 1.25	15472/3
65 (2-1/2")	15476/3	18133/2	M6 x 1.0	18133/1	18132/1	18131/1	S. 1151/8	18240/6	18240/2	N/A	18240/7	M10 x 1.5	18240/5
80 (3")	15479/3	15479/2	M6 x 1.0	15479/1	15478/1	15477/1	S. 1151/5	15478/7	15478/10	N/A	15478/14	M12 x 1.75	15478/13
90 (3-1/2")	16173/3	16173/2	M6 x 1.0	16173/1	16172/1	16171/1	S. 1151/6	16172/12	16172/17	N/A	16172/16	M12 x 1.75	16172/10
100 (4")	16176/3	16176/2	M6 x 1.0	16176/1	16175/1	16174/1	S. 1151/6	16172/12	16172/7	N/A	16172/16	M12 x 1.75	16172/2
125 (5")	15488/3	15488/2	M8 x 1.25	15488/1	15487/1	15486/1	S. 1151/7	16702/13	16702/9	M12 x 1.75	16702/16	M16 x 2.0	15487/2
150 (6")	16702/1	16702/3	M8 x 1.25	16702/2	16703/2	16704/1	S. 1151/7	16702/13	16702/9	M12 x 1.75	16702/16	M16 x 2.0	16702/12

Maintenance and Overhaul

- 1) Remove bolts and washers (20) which allows for the removal of adaptor (4).
- 2) Remove bellows subassembly and gasket of seal kit (5) and spacer (6). Note that for the 125 (5") and the 150 (6"), the locking screw (18) will need removing as spacer (16) is screwed RH thread and should be adjusted to give 6mm compression on the bellows subassembly during refitting.
- 3) Remove locking screws (7) from the rubbing ring of seal kit (5) through the bleed port in body S/A (19) and unscrew the rubbing ring (RH or LH thread) and remove the gasket and thrust pad (17).
- 4) Remove spindle (21) from body S/A (19) and check the bore of the carbon bearing and the bearing surface of the spindle for excessive wear.
- 5) If the adaptor (4) is Type R.S., remove locking screw (3), unscrew locking ring (1) and remove C/T bearing (2).
- 6) Replace seal kit (5) and thrust pad (17) at a minimum.
- 7) Replace body S/A (19) and spindle (21) depending on condition. If type RS, replace C/T bearing (2).
- 8) Thoroughly clean all parts before reassembly (which is virtually the reverse of the above steps).
- 9) Handle seal kits with care to avoid damaging the precision lapped seal faces.
- 10) After reassembly, follow the recommended installation procedures and allow for a suitable run-in to period ensure the seals are working correctly before refitting to the machine.

Minimum Length for Flexible Hose

Nominal Size	Length (mm)	Part Number
40 (1-1/2")	460	M.240/7
50 (2")	610	M.240/8
65 (2-1/2")	610	M.240/9
80 (3")	760	M.240/10
90 (3-1/2")	760	M.240/10
100 (4")	915	M.240/11
125 (5")	915	M.240/12
150 (6")	915	M.240/13

\* Note: For the 125 (5") and 150 (6") models, there is spacer (16) and a locking screw (18) which can be adjusted to give 6mm compression on the bellows subassembly if necessary.

Lubrication

The bellows seal fitted to the rotary C.B. union is self-adjusting within its working life. The union has dry carbon journal and thrust bearings operating on hardened surfaces. DO NOT GREASE. We advise periodic inspection for bearing wear.

# ADDITIONAL ROTARY UNION MODELS

## Additional Rotary Unions

A wide range of additional rotary unions are available depending on your particular requirements. Some of the more common models are listed below. Please contact us for additional information.

**1) Rotary (L.C.) Union:** The rotary L.C. union is intended for light duty applications where low pressures, low temperatures, modest speeds and occasional use is encountered. The simple design using the minimum amount of parts makes this union especially useful where there are space limitations (such as where two rotary shafts are close together) or where there is limited space between the shaft end and the machine frame. The L.C. union is intended mainly for onetime use, although repair is possible. (For continuous use and easy repair, we recommend switching instead to the Rotary R.E. or P.B. Models). The L.C. union is available in nominal sizes including 8(1/4"), 10(3/8"), 15(1/2") and 20(3/4") with two variations including a single flow Type B.E. and a double flow Type S.T.

**2) Rotary (P.N.) Union:** The rotary P.N. union has the same basic design as the L.C. union but also incorporates an oil lubrication reservoir for seal face lubrication. This type of union is intended primarily for use on **pneumatic applications** when the compressed air is dry, although even when lubricated air systems are in use, the P.N. union offers advantages over the L.C. union for certain applications. For example, if speeds are high or occasional pneumatic cycles are the norm, it is possible that very little lubricant reaches the seal faces and may be quickly dissipated by the seal face temperatures created by the natural friction. The oil reservoir of the P.N. union adds protection in these types of conditions. The P.N. union is available in nominal sizes including 8(1/4"), 10(3/8"), 15(1/2") and 20(3/4"). Type B.E. is generally the only model offered since pneumatic applications are usually single flow, but Type S.T. can be supplied if you require double flow.

**3) Rotary (M.C.T.) Union:** The rotary M.C.T. union is intended for **machine tools applications** for the transfer of fluids (such as oil and air) to and from rotating shafts for air and hydraulic chuck, brakes, clutches, etc. The type of rotary seal fitted to this model is a Filton® Balanced Mechanical Seal containing multiple helical coil springs. The seal face materials are normally carbon against stainless steel. For applications on machine tool coolants where traces of abrasive particles may be present, tungsten carbide seals are also available. Rotary sealing is created by relative rotation between extremely flat sealing faces (see item #2 and #4 in diagram) held in contact by the helical coil springs and the additional sealing force created by the pressure of the fluid passing through the union. The bearings fitted to the union are a matched pair of pre-loaded angular contact bearings lubricated for life with a special grease. A double range of M.C.T. unions is offered with the machine end connection having parallel pipe threads (RH or LH) for speeds up to 1,500 r.p.m. and with an additional concentric locating spigot for speeds up to 3,000 r.p.m. The M.C.T. union is available in nominal sizes including 8(1/4"), 10(3/8"), 15(1/2"), 20(3/4") and 25(1") with three variations including a single flow Type B.E., a double flow stationary tube Type S.T. and a double flow rotating tube Type R.S.

**4) Rotary (I.N.T.) Union:** The rotary I.N.T. union is intended for **limited space applications** between the roll end and the machine frame. The terminus of the roll is bored out to accept this self-contained union and the rotary parts are held in place by a clamping ring which is part of the roll end design. The services must be connected with flexible hose. The rotary seal fitted to this model is a Filton® Bellows Seal identical to the seals fitted in the rotary R.E. union. An alternative mechanical seal is also available for higher pressures and speeds. The I.N.T. union is available in nominal sizes including 8(1/4"), 10(3/8"), 15(1/2"), 20(3/4") and 25(1") with two variations including a single flow Type B.E. and a double flow stationary tube Type S.T.

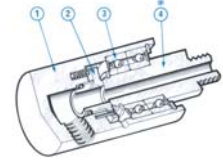

**ROTARY L.C. UNION**

1. Body
2. Mechanical seal assembly
3. Ball bearings (life lubricated)
4. Rotary Spindle

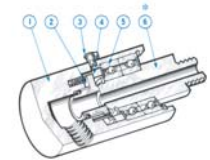

**ROTARY P.N. UNION**

1. Body
2. Mechanical seal assembly
3. Seal face lubricator
4. Oil reservoir
5. Ball bearings (life lubricated)
6. Rotary spindle

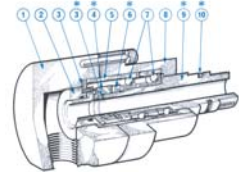

**ROTARY M.C.T. UNION**

1. Adaptor, aluminum alloy
2. Mechanical seal subassembly
3. Gaskets
4. Seal ring subassembly
5. Spacer, plated steel
6. Locking ring, steel
7. Angular contact bearings
8. Body, aluminum alloy
9. Rotary spindle, plated steel
10. 'O' ring, synthetic rubber

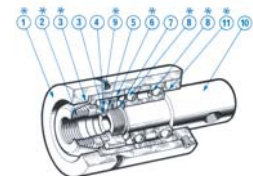

**ROTARY I.N.T. UNION**

1. Body, plated steel
2. Bellows subassembly
3. Gaskets
4. Seal ring subassembly
5. Locking screw, h.t. steel
6. Spacer
7. Circlip, spring steel
8. Ball bearings
9. 'O' ring, nitrile rubber
10. Spindle, steel
11. Locking ring, steel

(\*) Rotates with the shaft

## Special Rotary Union Models

A wide range of specialty rotary unions are also available depending on your particular requirements. A few of the more common examples include:

### 1) 3-Port Rotary Unions

These unions are manufactured on a special basis but can at times be made available using the basic bearing housing and main seal from any of the standard rotary union offerings. The example shown in the diagram illustrates a typical construction using two rotating centre tubes for three flow channels. Depending on the conditions of the application, Filton® Bellows Seals or Filton® Mechanical Seals are used between each flow channel. If it is essential to prevent any “cross-talk” between channels, then a double seal having a bleed to atmosphere can be incorporated.

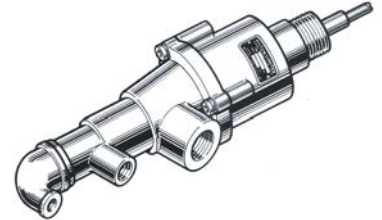

### 2) Piggyback Rotary Unions

For certain applications, it can be useful to keep multi-flow channels completely separate when using different fluids. The example shown illustrates a combined unit having two channels for hydraulic oil and piggybacked on the outboard end is a rotary P.N. union for a pneumatic service. It is possible to apply this principle to more than three channels. In some cases, six channel main units with two channel rotary unions piggybacked have been designed (making eight channels available in total).

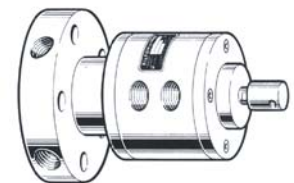

### 3) Liquid Bottling / Canning Rotary Unions

For bottling and canning applications, specially designed rotary unions are often required. Multichannel systems are generally used with facilities for compressed air, carbon dioxide, nitrogen and C.I.P. (cleaning-in-place) systems. The example shown illustrates connections for C.I.P. compressed air, carbon dioxide and (on the top) an electrical slip ring system for instrumentation and control. Connections are available for any of the standard C.I.P. systems including RJT, ISS, DIN or TRICLOVER.

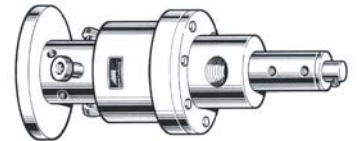

### 4) Multi-Port Rotary Unions

In certain situations, the machinery requirements may be impossible to satisfy with one of the standard rotary unions offered in this manual. It may become necessary to custom manufacture a multi-channel design. A wide range of multi-port design options are available in various materials including aluminum, bronze, carbon steel, stainless steel and nickel alloys. The example illustrated is a six-channel unit built on a sectional body basis with a tie bar system. Solid body designs are also used depending on the application and specifications.

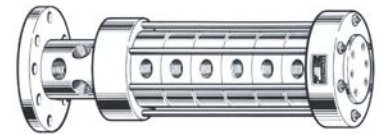

Examples of applications where multi-port rotary unions are useful include a vast range of cooling, heating, hydraulic, pneumatic and vacuum conditions. It is also feasible to design unions for the transfer of electrical services including power slip rings and brushes or instrumentation and control mechanisms. Please contact us for additional information.

### 5) Overshaft Rotary Unions

The rotary unions outlined in this manual are designed for connecting to the end of a rotating shaft. There are certain applications, however, where end access is impossible and it becomes necessary to transfer services at some point along the shaft. The diagram shown illustrates an example of an overshaft rotary union with two services passing into and axially along the machine shaft. In certain conditions, it is also possible to incorporate the rotary connection into the rotary union sleeve for transferring services externally along a shaft.



As a general guideline, it is recommended to make every effort to obtain shaft end access whenever possible. Overshaft rotary unions are costly and can require major machinery dismantling for installation, servicing and removal operations.

# SPECIAL CONNECTIONS AND ACCESSORIES

## Special Connections - Screw Threads

The standard connection threads are 'G' pipe threads to BS.2779 and ISO.288/1 (formerly B.S.P. Parallel). A number of variations are available depending on machine requirements including some of the more common alternatives that are listed below in the charts (add the required code to the suffix of the part number). All rotary connections threads (indicated by dimension 'A'), can be provided with RH or LH threads to suit the direction of rotation. For other variations, please contact us.

Code	Spindle Thread 'A' (RH or LH)	Adapter Threads 'B' 'N' and 'O'
F	'G' pipe thread (parallel) female	'G' pipe thread (parallel)
M.B.	Metric thread (see additional chart)	'G' pipe thread (parallel)
M.N.	Metric thread (see additional chart)	N.P.T.
N.P.T.	N.P.T.	'G' pipe thread (parallel)
N.P.T.2	N.P.T.	N.P.T.
N.P.T.3	'G' pipe thread (parallel)	N.P.T.
P.P.	A.P.P.T / NPSM	'G' pipe thread (parallel)
P.P.N.	A.P.P.T / NPSM	N.P.T.
T.R.	'R' pipe thread (taper)	'G' pipe thread (parallel)
T.R.2	'R' pipe thread (taper)	'R' pipe thread (taper)
U	Unified Thread (see additional chart)	'G' pipe thread (parallel)
U.N.	Unified Thread (see additional chart)	N.P.T.

Nominal Size	Spindle Thread 'A' (RH or LH)	
	Unified (Code U)	Metric (Code M)
8 (1/4")	1/2" - 20 U.N.F.	M12 x 1.25
10 (3/8")	5/8" - 18 U.N.F.	M15 x 1.50
15 (1/2")	3/4" - 16 U.N.F.	M22 x 1.50
20 (3/4")	1" - 14 U.N.S.	M30 x 1.50
25 (1")	1 1/2" - 12 U.N.F.	M35 x 1.50
32 (1-1/4")	1 3/4" - 12 U.N.	M40 x 1.50
40 (1-1/2")	2" - 12 U.N.	M50 x 1.50
50 (2")	2 1/2" - 12 U.N.	M60 x 2.00
65 (2-1/2")	3" - 12 U.N.	M76 x 2.00
80 (3")	3 1/2" - 12 U.N.	M90 x 2.00

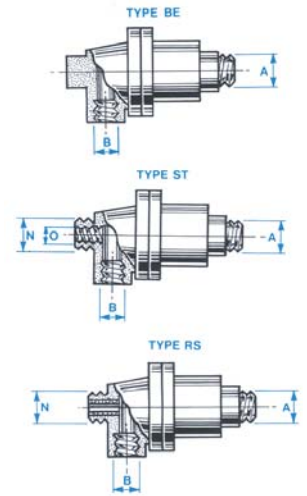

- (i) If an alternative female spindle thread is required for the spindle thread 'A', add the prefix 'F' to the appropriate thread code.
- (ii) 'G' pipe threads are to BS.2779 and ISO 228/1 (formerly B.S.P. parallel).
- (iii) 'R' pipe threads are to BS.21 and ISO 7/1 (formerly B.S.P. taper).

## Special Connections - Flanges

For applications where standard threaded connections are unsuitable, rotary unions with flanged interfaces are also available. Some examples where this might occur include:

- 1) Applications in which the shaft is regularly changing direction from clockwise to anti-clockwise. The rotation could potentially unscrew a threaded unit.
- 2) Situations where the temperature exceeds 200°C. For high temperature applications, a range of flanged rotary H.T.F. unions are also available - please contact us for more information.
- 3) Rotary union model sizes including 125 (5') and 150 (6') where the use of a flange facilitates the ease of installation, maintenance and removal.

The most common types of spindle flange designs are shown in the diagram to the right. Specials can be manufactured to suit virtually any shaft end dimensions that may be required and, if flanges are required for the stationary connections, these can be provided to any of the National or International specifications including: A.F.N.O.R., A.N.S.I., BS.10, BS.1560, BS.4504, D.I.N. and I.S.O. For all new design work where equipment is to be used in the European community, we recommend in particular the BS.4504 standard.

In the case of applications in which the flange itself rotates, special care must be taken during the design stage as concentric mounting is essential. These rotating flanges can be based on any of the standard flange specifications, but they will require a concentric location spigot or recess.

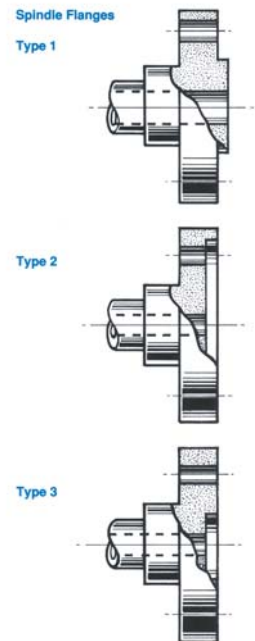

# SPECIAL CONNECTIONS AND ACCESSORIES

## Standard Spindle Flange Sizes and Dimensions

The most common spindle flange sizes are listed in the chart below. Specials can be manufactured to suit virtually any shaft end dimension and there are a number of custom options available.

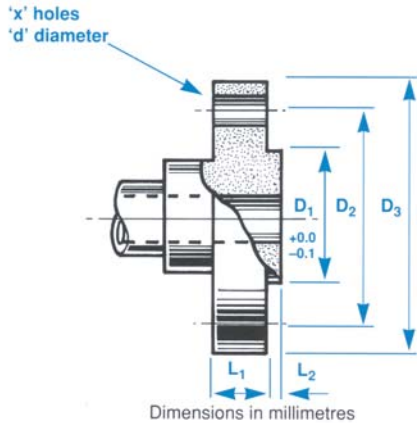

Nominal Size	D1	D2	D3	L1	L2	x	d
15 (1/2")	45	65	95	14	6	4	14
20 (3/4")	58	75	105	16	6	4	14
25 (1")	68	85	115	16	6	4	14
32 (1-1/4")	78	100	140	18	6	4	18
40 (1-1/2")	88	110	150	18	6	4	18
50 (2")	102	125	165	20	6	4	18
65 (2-1/2")	122	145	185	20	8	4	18
80 (3")	138	160	200	20	8	8	18
100 (4")	158	180	220	22	8	8	18
125 (5")	188	210	250	22	10	8	18
150 (6")	212	240	285	22	10	8	22

## Rotary Union Accessories

A number of accessories are available to assist with the maintenance and installation of rotary unions for your particular application. For additional information and technical assistance, please contact us.

### 1) Syphon Elbows

The Filton® Syphon Elbow is a useful accessory with for the rotary P.B., R.E.B., C.B. and C.B.N. unions (type S.T.) whenever there is a steam service. The majority of steam cylinders are fitted with a curved syphon tube for condensate extraction. If the diameter to length ratio of the cylinder end bore prevents the use of a curved syphon tube from being fitted, the syphon elbow should be used (see illustrations below). The elbow allows two pieces of straight pipe to be joined and the hinge opens to allow for fitting through the bore of the cylinder end. It is advisable to fit the syphon tube to port 'O' of the rotary union type S.T., locking it with a backnut and checking the down pipe position in relation to port 'B' before installation.

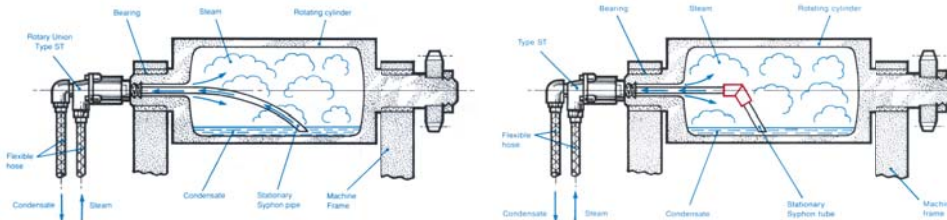

The syphon tube assembly is cantilevered from port 'O' in the rotary union. In certain applications, the syphon tube length and weight can cause too much deflection and load on the rotary union bearings; it is therefore sometimes necessary to include a syphon tube support bearing within the cylinder.

# ROTARY UNION ACCESSORIES

## Syphon Elbows (Continued)

The standard materials used for syphon elbow construction include brass for the body, stainless steel for the hinge and fluorocarbon for the sealing ring. For heavy syphon tubes and corrosive conditions, the bodies may also be provided in stainless steel (add the code 'S' to part number). To select a suitable syphon elbow, check the centre tube thread (dimension 'O' of the rotary union) and match it to thread 'A.'

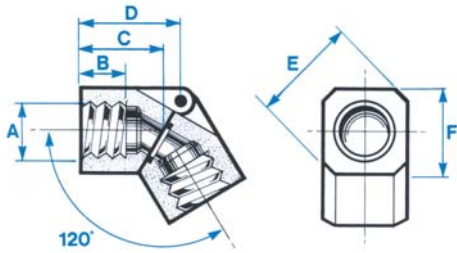

Nominal Size	Part Number	Dimensions (mm unless specified otherwise)					
		A <sup>(i)</sup>	B	C	D	E	F
8 (1/4")	14961	G. 1/4"	9.5	19.0	22.2	22.9	19.1
10 (3/8")	14940	G. 3/8"	12.7	27.0	31.8	29.5	22.2
15 (1/2")	14962	G. 1/2"	15.8	28.6	34.1	36.3	28.6
20 (3/4")	14963	G. 3/4"	19.0	34.9	42.9	42.7	34.9

<sup>(i)</sup> "G" is the designation for parallel pipe threads to BS.2779 and ISO 228/1.

## 2) Flexible Hoses

The table and diagrams provided illustrate the standard range of flexible hoses for use with all models of rotary unions for water, steam, low pressure oil and hot oil services. The lengths shown are the minimum recommended to provide the necessary curvature and flexibility for connection purposes. As well as the standards indicated, custom lengths to specific requirements can be supplied including a variety of end fittings. The more common end fittings requested are illustrated on the right. Alternative pipe threads are also available including, for example, NPT. The standard materials used for flexible hoses include stainless steel for the convoluted tube, stainless steel for the external reinforcing braid and mild steel for the end fittings. The end fittings are fixed male to swivel male and the assembly is welded and pressure tested.

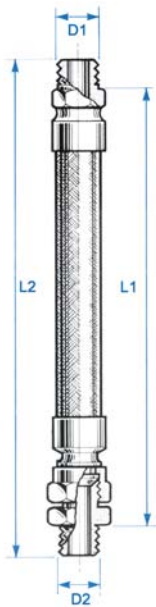

Part Number	Dimensions (mm unless specified otherwise)			Minimum Centre Line Bend Radius	Maximum Pressure Bar
	D <sup>(ii)</sup>	L1	L2		
M240/1	R. 1/4"	150	182	102	77
M240/2	R. 3/8"	230	262	152	60
M240/3	R. 1/2"	305	343	203	60
M240/4	R. 3/4"	305	343	191	41
M240/5	R. 1"	380	424	261	34
M240/6	R. 1 1/4"	460	517	229	27
M240/7	R. 1 1/2"	460	517	254	25
M240/8	R. 2"	610	667	279	24
M240/9	R. 2 1/2"	610	674	330	17
M240/10	R. 3"	760	831	381	17
M240/11	R. 4"	915	1016	500	17
M240/12	R. 5"	915	1035	740	17
M240/13	R. 6"	915	1042	970	17

<sup>(ii)</sup> 'R' is the designation for tapered pipe threads to BS21 and ISO 7/1 (formerly designated B.S.P. taper).

If flanged fittings are required, one flange should be a swivel type to aid stress-free fitting. A swivel flange should always be used if the opposite end is a fixed threaded type. Flanges are available to the following specifications: A.F.N.O.R., A.N.S.I., BS.10, BS.1560, BS.4504, D.I.N. and I.S.O.

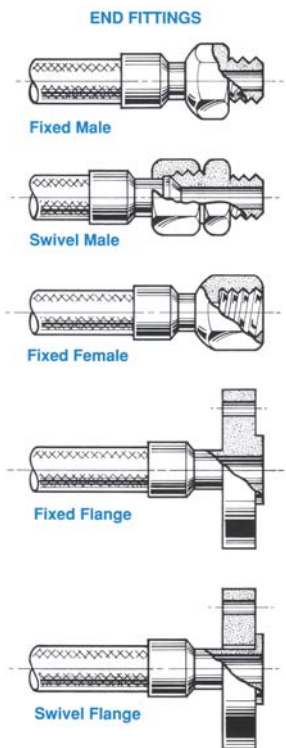

# TYPICAL APPLICATIONS HEALTH AND SAFETY

## Typical Applications

### 1) Type B.E. - Single Flow

The application example shown is typical on a drilled roll of a plastics calendar. Fluids transferred are generally water, oil or heat transfer oil.

### 2) Type S.T. - Double Flow (Stationary Center Tube)

The application example shown is typical on a steam heated cylinder in a paper dryer.

### 3) Type R.S. - Double Flow (Rotary Center Tube)

The application example shown is typical on a water cooled roll of a rubber mill.

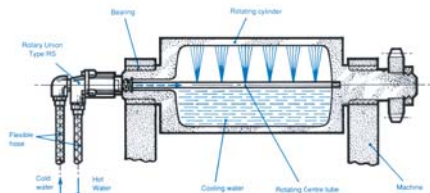
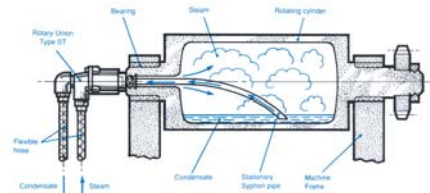
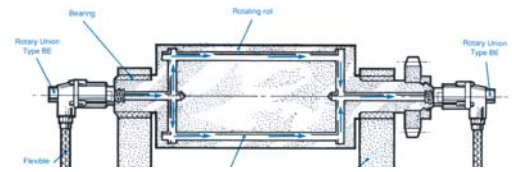

## Health and Safety

- The rotary unions illustrated within this catalogue should not present any hazard when correctly fitted, installed, maintained and operated within the normal conditions and parameters as outlined by the specifications provided. To ensure satisfactory performance, all unions are run-in and leakage tested before shipping. Please note that dismantling units will invalidate the warranty.
- It is essential to use the correct hand of rotary connection thread to ensure that the union will not unscrew (see the installation instructions for additional information). If a shaft reverses rotation while under operating conditions then the union must be locked or, preferably, a flanged connection should be used.
- Prior to any maintenance, repair or removal, be sure to depressurize and drain the system to avoid injury.
- Do not exceed or combine maximums as outlined under the maximum operating conditions for each rotary union model. When in doubt, please contact us for additional information to ensure safe, satisfactory performance.
- At some point, the seals in a rotary union will leak. Regular daily inspection is recommended. Ensure that any leakages are not hazardous to personnel or equipment and be sure to fit protective guards when appropriate. Repair any leaks immediately to avoid the possibility of extensive damage. If leakages are not attended to promptly, bearing seizure is possible which can lead to flexible hose failure and potentially massive leakage. As a preventative measure for certain hazardous applications, an excess torque detector can be fitted to stop a machine before major damage occurs.
- With oil systems, minor leakages are normal and will occur resulting from the natural characteristics of oil which prevents the seal faces from contacting fully.
- Also note: for all rotary union models currently manufactured, non-asbestos gaskets have replaced all of the compressed asbestos fibre material that was used previously. Existing units may still contain asbestos and should be handled and disposed with care according to asbestos product safety regulations.

# CROSS REFERENCE TABLES

Part Number	Replacement Number	Rotary Union - Description			Seal Kit
		Nominal Size	Model	Type	
14377	--	32 (1 1/4")	R.E.	B.E.	S1100/4
14379	--	32 (1 1/4")	R.E.	S.T.	S1100/4
14385	15472	50 (2")	C.B.N.	S.T.	S1151/4
14386	--	25 (1")	C.B.	S.T.	S1100/3
14396	--	25 (1")	R.E.	B.E.	S1100/3
14397	16660	20 (3/4")	C.B.	R.S.	S1100/2
14398	16664	32 (1 1/4")	C.B.	R.S.	S1100/4
14460	--	20 (3/4")	R.E.	B.E.	S1100/2
14486	15473	50 (2")	C.B.N.	R.S.	S1151/3
14488	--	32 (1 1/4")	C.B.	S.T.	S1100/4
14502	16661	25 (1")	R.E.	R.S.	S1100/3
14523	--	20 (3/4")	C.B.	S.T.	S1100/2
14524	--	20 (3/4")	C.B.	B.E.	S1100/2
14525	--	15 (1/2")	C.B.	S.T.	S1100/2
14534	--	20 (3/4")	R.E.	S.T.	S1100/2
14535	--	15 (1/2")	R.E.	S.T.	S1100/2
14536	--	15 (1/2")	R.E.	B.E.	S1100/2
14541	16663	32 (1 1/4")	R.E.	R.S.	S1100/4
14542	--	25 (1")	R.E.	S.T.	S1100/3
14543	16659	20 (3/4")	R.E.	R.S.	S1100/2
14544	16662	25 (1")	C.B.	R.S.	S1100/3
14545	--	25 (1")	C.B.	B.E.	S1100/3
14546	--	32 (1 1/4")	C.B.	B.E.	S1100/4
14551	17238	50 (2")	R.E.B.	S.T.	S1171/4
14552	17350	50 (2")	R.E.B.	B.E.	S1171/4
14553	17351	50 (2")	R.E.B.	R.S.	S1171/4
14554	--	15 (1/2")	C.B.	B.E.	S1100/2
14555	16658	15 (1/2")	C.B.	R.S.	S1100/2
14556	16657	15 (1/2")	R.E.	R.S.	S1100/2
14562	18105	40 (1 1/2")	R.E.B.	S.T.	S1151/3
14563	18104	40 (1 1/2")	R.E.B.	B.E.	S1151/3
14564	18106	40 (1 1/2")	R.E.B.	R.S.	S1151/3
14565	18102	40 (1 1/2")	C.B.N.	S.T.	S1151/3
14566	18101	40 (1 1/2")	C.B.N.	B.E.	S1151/3
14567	18103	40 (1 1/2")	C.B.N.	R.S.	S1151/3
14574	15471	50 (2")	C.B.N.	B.E.	S1151/4
14624	17265	80 (3")	R.E.B.	B.E.	S1171/5
14625	17266	80 (3")	R.E.B.	S.T.	S1171/5
14626	17263	80 (3")	R.E.B.	R.S.	S1171/5
14627	15477	80 (3")	C.B.N.	B.E.	S1151/5
14628	15478	80 (3")	C.B.N.	S.T.	S1151/5
14629	15479	80 (3")	C.B.N.	R.S.	S1151/3
14630	18131	65 (2 1/2")	R.E.B.	B.E.	S1171/8
14631	18132	65 (2 1/2")	R.E.B.	S.T.	S1171/8
14632	18133	65 (2 1/2")	R.E.B.	R.S.	S1171/8
14633	18240	65 (2 1/2")	C.B.N.	B.E.	S1151/8

Part Number	Replacement Number	Rotary Union - Description			Seal Kit
		Nominal Size	Model	Type	
14634	18241	65 (2 1/2")	C.B.N.	S.T.	S1151/8
14635	18242	65 (2 1/2")	C.B.N.	R.S.	S1151/8
14636	--	10 (3/8")	R.E.	B.E.	S1100/1
14637	--	10 (3/8")	R.E.	S.T.	S1100/1
14638	17197	10 (3/8")	R.E.	R.S.	S1100/1
14639	--	10 (3/8")	C.B.	B.E.	S1100/1
14640	--	10 (3/8")	C.B.	S.T.	S1100/1
14641	17216	10 (3/8")	C.B.	R.S.	S1100/1
14642	--	8 (1/4")	R.E.	B.E.	S1100/1
14643	--	8 (1/4")	R.E.	S.T.	S1100/1
14644	17196	8 (1/4")	R.E.	R.S.	S1100/1
14645	--	8 (1/4")	C.B.	B.E.	S1100/1
14646	--	8 (1/4")	C.B.	S.T.	S1100/1
14647	17215	8 (1/4")	C.B.	R.S.	S1100/1
15441	17350	50 (2")	R.E.B.	B.E.	S1171/4
15442	17238	50 (2")	R.E.B.	S.T.	S1171/4
15443	17351	50 (2")	R.E.B.	R.S.	S1171/4
15444	18131	65 (2 1/2")	R.E.B.	B.E.	S1171/8
15445	18132	65 (2 1/2")	R.E.B.	S.T.	S1171/8
15446	18133	65 (2 1/2")	R.E.B.	R.S.	S1171/8
15447	17265	80 (3")	R.E.B.	B.E.	S1171/5
15448	17266	80 (3")	R.E.B.	S.T.	S1171/5
15449	17263	80 (3")	R.E.B.	R.S.	S1171/5
15471	--	50 (2")	C.B.N.	B.E.	S1151/4
15472	--	50 (2")	C.B.N.	S.T.	S1151/4
15473	--	50 (2")	C.B.N.	R.S.	S1151/4
15474	18240	65 (2 1/2")	C.B.N.	B.E.	S1151/8
15475	18241	65 (2 1/2")	C.B.N.	S.T.	S1151/5
15476	18242	65 (2 1/2")	C.B.N.	R.S.	S1151/8
15477	--	80 (3")	C.B.N.	B.E.	S1151/5
15478	--	80 (3")	C.B.N.	S.T.	S1151/5
15479	--	80 (3")	C.B.N.	R.S.	S1151/3
15486	--	125 (1")	C.B.N.	B.E.	S1151/7
15487	--	125 (1")	C.B.N.	S.T.	S1151/7
15488	--	125 (1")	C.B.N.	R.S.	S1151/7
16171	--	90 (3 1/2")	C.B.N.	B.E.	S1151/6
16172	--	90 (3 1/2")	C.B.N.	S.T.	S1151/6
16173	--	90 (3 1/2")	C.B.N.	R.S.	S1151/6
16174	--	10 (3/8")0	C.B.N.	B.E.	S1151/6
16175	--	10 (3/8")0	C.B.N.	S.T.	S1151/6
16176	--	10 (3/8")0	C.B.N.	R.S.	S1151/6
16657	--	15 (1/2")	R.E.	R.S.	S1100/2
16658	--	15 (1/2")	C.B.	R.S.	S1100/2
16659	--	20 (3/4")	R.E.	R.S.	S1100/2
16660	--	20 (3/4")	C.B.	R.S.	S1100/2
16661	--	25 (1")	R.E.	R.S.	S1100/3

# CROSS REFERENCE TABLES

Part Number	Replacement Number	Rotary Union - Description			Seal Kit
		Nominal Size	Model	Type	
16662	--	25 (1")	C.B.	R.S.	S1100/3
16663	--	32 (1 1/4")	R.E.	R.S.	S1100/4
16664	--	32 (1 1/4")	C.B.	R.S.	S1100/4
16667	18106	40 (1 1/2")	R.E.B.	R.S.	S1151/3
16668	18103	40 (1 1/2")	C.B.N.	R.S.	S1151/3
16675	17351	50 (2")	R.E.B.	R.S.	S1171/4
16676	15473	50 (2")	C.B.N.	R.S.	S1151/4
16677	18133	65 (2 1/2")	R.E.B.	R.S.	S1171/8
16678	18242	65 (2 1/2")	C.B.N.	R.S.	S1151/8
16679	17263	80 (3")	R.E.B.	R.S.	S1171/5
16680	15479	80 (3")	C.B.N.	R.S.	S1151/5
16702	--	150 (6")	C.B.N.	R.S.	S1151/7
16703	--	150 (6")	C.B.N.	S.T.	S1151/7
16704	--	150 (6")	C.B.N.	B.E.	S1151/7
17196	--	8 (1/4")	R.E.	R.S.	S1100/1
17197	--	10 (3/8")	R.E.	R.S.	S1100/1
17215	--	8 (1/4")	C.B.	R.S.	S1100/1
17216	--	10 (3/8")	C.B.	R.S.	S1100/1
17238	--	50 (2")	R.E.B.	S.T.	S1171/4
17241	--	90 (3 1/2")	R.E.B.	B.E.	S1151/6
17242	--	90 (3 1/2")	R.E.B.	S.T.	S1151/6
17243	--	90 (3 1/2")	R.E.B.	R.S.	S1151/6
17263	--	80 (3")	R.E.B.	R.S.	S1171/5
17265	--	80 (3")	R.E.B.	B.E.	S1171/5
17266	--	80 (3")	R.E.B.	S.T.	S1171/5
17350	--	50 (2")	R.E.B.	B.E.	S1171/4
17351	--	50 (2")	R.E.B.	R.S.	S1171/4
17352	18131	65 (2 1/2")	R.E.B.	B.E.	S1171/8
17353	18132	65 (2 1/2")	R.E.B.	S.T.	S1171/8
17354	18133	65 (2 1/2")	R.E.B.	R.S.	S1171/8
17424	--	10 (3/8")0	R.E.B.	B.E.	S1151/6
17425	--	10 (3/8")0	R.E.B.	S.T.	S1151/6
17425	--	10 (3/8")0	R.E.B.	R.S.	S1151/6
17634	--	125 (1")	R.E.B.	B.E.	S1151/7
17635	--	125 (1")	R.E.B.	S.T.	S1151/7
17636	--	125 (1")	R.E.B.	R.S.	S1151/7
17637	--	150 (6")	R.E.B.	B.E.	S1151/7
17638	--	150 (6")	R.E.B.	S.T.	S1151/7
17639	--	150 (6")	R.E.B.	R.S.	S1151/7
18101	--	40 (1 1/2")	C.B.N.	B.E.	S1151/3
18102	--	40 (1 1/2")	C.B.N.	S.T.	S1151/3
18103	--	40 (1 1/2")	C.B.N.	R.S.	S1151/3
18104	--	40 (1 1/2")	R.E.B.	B.E.	S1151/3
18105	--	40 (1 1/2")	R.E.B.	S.T.	S1151/3
18106	--	40 (1 1/2")	R.E.B.	R.S.	S1151/3
18131	--	65 (2 1/2")	R.E.B.	B.E.	S1171/8

Part Number	Replacement Number	Rotary Union - Description			Seal Kit
		Nominal Size	Model	Type	
18132	--	65 (2 1/2")	R.E.B.	S.T.	S1171/8
18133	--	65 (2 1/2")	R.E.B.	R.S.	S1171/8
18240	--	65 (2 1/2")	C.B.N.	B.E.	S1151/8
18241	--	65 (2 1/2")	C.B.N.	S.T.	S1151/8
18242	--	65 (2 1/2")	C.B.N.	R.S.	S1151/8
18466	--	15 (1/2")	P.B.	B.E.	S1100/2
18467	--	15 (1/2")	P.B.	S.T.	S1100/2
18468	--	15 (1/2")	P.B.	R.S.	S1100/2
18469	--	20 (3/4")	P.B.	B.E.	S1100/2
18470	--	20 (3/4")	P.B.	S.T.	S1100/2
18471	--	20 (3/4")	P.B.	R.S.	S1100/2
18472	--	15 (1/2")	P.B.	B.E.	--
18473	--	15 (1/2")	P.B.	S.T.	--
18474	--	15 (1/2")	P.B.	R.S.	--

## About Filton Ltd.

Filton Ltd. is a private limited company that was founded in 1942 and is currently located in Royal Leamington Spa, England. Originally created to manufacture conventional leather oil seals for rotary shafts, Filton Ltd. has evolved into one of the world's leading manufacturers of rotary sealing products using state of the art designs and sophisticated sealing face materials. If a suitable design is not already available to meet your application needs, the Filton design team is standing by to create a custom solution according to your specifications. All products are rigorously inspected during manufacture and every rotary union is pressure tested prior to shipping in order to ensure your complete satisfaction.

## Please Note:

The information, data and tables contained in this catalogue have been carefully edited at the time publication. However, no responsibility for possible errors or omissions can be assumed. We reserve the right to change specifications and other information without notice. Duplication in whole or in part without prior written consent is prohibited.

©Nuraseal Co. Ltd.

**For nearly three decades**, Nuraseal has been providing sales and service for all Filton® Rotary Union Products. Whether you require new or custom unions, replacement components, technical support or assistance with maintenance inquiries, Nuraseal will be able to help you solve your application requirements throughout North America and abroad. Contact us to find out how we can help you today!

Need Help? Here's what to do before you call. . . **Toll Free ! 1-888-NURASEAL (687-2732)**

In order to better serve your needs, it is helpful to collect some basic information prior to contacting us. Most of this information will be located on a plate fastened to the unit itself or easily identified by visual inspection.

- Rotary Union Model type i.e. Rotary R.E. Union
- Part number i.e. 16663.
- Serial number - generally identified either by a combination of two letters followed by four numbers or four numbers followed by a single letter i.e. ZN5631
- Nominal size
- Direction of rotation - if there is a groove in the spindle, it is a left-hand thread.

Other information that is helpful, especially when trying to select a suitable model or when troubleshooting during times of maintenance or unit failure, include:

- Type of fluid, flow rate, pressure, temperature
- Ambient temperature
- Rotational speed
- Working cycle
- Any unusual conditions i.e. exposure to harsh environments, etc.

### Quick Selection and Reference Guide

Check the Application Requirement column below for the appropriate fluid and size range. Turn to the page for the model indicated and check the full working conditions and limitations. If more than one model is indicated, examine the application information on the appropriate pages. Contact us for more information.

Application Requirements								Rotary Union Model Type	Available Size Range <sup>(1)</sup>	Page Reference
Air	Gas <sup>(3)</sup>	Oil (Lubricating)	Oil (Hydraulic)	Oil (Heat Transfer)	Steam	Vacuum	Water			
Y <sup>(2)</sup>	Y	Y	--	Y	Y	Y	Y	R.E.	8 (1/4") - 32 (1 1/4")	Page 4
Y <sup>(2)</sup>	Y	Y	--	--	--	Y	Y	P.B.	15 (1/2") - 25 (1")	Page 8
Y <sup>(2)</sup>	Y	Y	--	Y	Y	Y	Y	R.E.B.	40 (1 1/2") - 150 (6") <sup>(5)</sup>	Page 12
--	--	--	--	Y <sup>(4)</sup>	Y	--	Y	C.B.	8 (1/4") - 32 (1 1/4")	Page 16
--	--	--	--	Y <sup>(4)</sup>	Y	--	Y	C.B.N.	40 (1 1/2") - 150 (6") <sup>(5)</sup>	Page 20
Y <sup>(2)</sup>	--	Y	--	--	--	--	Y	L.C.	8 (1/4") - 20 (3/4")	Page 24
Y	--	--	--	--	--	Y	--	P.N.	8 (1/4") - 20 (3/4")	Page 24
Y <sup>(2)</sup>	Y	Y	Y	--	--	Y	--	M.C.T.	8 (1/4") - 25 (1")	Page 24
Y <sup>(2)</sup>	--	Y	Y	--	--	Y	Y	I.N.T.	8 (1/4") - 25 (1")	Page 24

#### Legend:

- (Y) Suitable for your application, but check the working condition information
- (1) Size range as measured at the rotary spindle connection end
- (2) Lubricated air only (if air is dry and P.N. model is unsuitable, special seals are available)
- (3) Depends on type of gas and working conditions
- (4) Flanges may be required depending on the working conditions
- (5) Flanges may be fitted to assist for removal and maintenance on sizes 100 (4") and larger.

### ALSO AVAILABLE



Swivel Joints



Mechanical & Specialty Seals



Air Breather Filters



996-B5 Westport Cres.  
Mississauga, Ontario CANADA  
L5T 1G1

Phone: (905) 795-8380  
Fax: (905) 795-8381

Toll Free:  
1-888-NURASEAL (687-2732)

www.nuraseal.com  
info@nuraseal.com